

CO  
SM  
O



DISP L A Y  
T O W E R  
C A B I N E T





## COSMO

**Cosmo: oltre  
la vetrina.  
La vetrina, oltre.**

Cosmo: beyond  
the showcase.  
The showcase, beyond.

*Nell'armonia del Cosmo è racchiusa  
la meraviglia della creazione.*

*Eleganza nelle forme, performance elevate,  
innovazione e affidabilità. Sono queste le  
caratteristiche che fanno di Cosmo una vera  
e propria esperienza sensoriale per un ricordo  
senza fine.*

*Sintesi di tecnologia e design, grazie alle quali  
i professionisti possono mostrare e dare valore  
alle loro creazioni.*

*Food appeal, capacità espositiva e performance  
elevate: con Cosmo, Orion alza gli standard  
di qualità, prestazioni e design, garantendo  
l'eccellenza della refrigerazione anche in  
condizioni ambientali estreme.*

*The wonders of creation  
are found in the harmony of Cosmo.*

*Elegant shapes, high performance, innovative  
and reliable. These are the characteristics that  
make Cosmo a true sensory experience for  
endless memories.*

*It is a combination of technology and design,  
thanks to which professionals can show and give  
value to their creations.*

*Food appeal, displaying ability and high  
performance: with Cosmo, Orion increases its  
standards of quality, performance and design,  
guaranteeing refrigeration excellence even in  
extreme environmental conditions.*

**ORION**

## Verticalità e bellezza

Verticality and beauty

02

Se in architettura il design verticale costituisce un modo innovativo di abitare, in grado di rivoluzionare la vita nelle metropoli contemporanee sia a livello di estetica che di funzionalità, così anche nel mondo dell'arredamento dei locali la scelta di servirsi di un armadio a vetri refrigerato rappresenta la soluzione ideale, e non solo per ottimizzare lo spazio: grazie al suo restyling che ne esalta la bellezza e l'eleganza nel design, Cosmo è diventato un punto di riferimento all'interno di ogni locale del settore F&B.

If vertical design in architecture is an innovative way of living, capable of changing life in contemporary cities, both in terms of aesthetics and functionality, in the world of interior furnishing the choice of a refrigerated display cabinet in glass is the ideal solution, and not only to optimise space: thanks to its restyling that enhances beauty and design elegance, Cosmo has become a point of reference for venues of all kinds in the F&B sector.



03



Modernità, trasparenza, luminosità, funzionalità, efficienza. Sono queste le caratteristiche principali di uno dei prodotti più richiesti nel settore del food. Evoluzione nello stile e nel design, unita a una tecnologia avanzata, hanno reso Cosmo una vetrina verticale diversa da tutte le altre.

Modernity, transparency, brightness, functionality, and efficiency. These are the main features of one of the most sought-after products in the food sector. The evolution of style and design, combined with advanced technology, made Cosmo a vertical display case different from all others.

04



## + Luminoso + Moderno + Green + Cosmo

+ Bright + Modern  
+ Green + Cosmo

 **BT**  
-18°/-20°

 **T+**  
+4°/+6°

 **T+S**  
+4°/+6°

 **T+V**  
+4°/+6°

 **NO FROST**  
-20°/+5°

Cosmo soddisfa l'esigenza dei professionisti della ristorazione per la conservazione e l'esposizione dei prodotti, senza rinunciare al lusso di un design stupefacente e all'avanguardia. La novità di restyling più importante è rappresentata dall'utilizzo di nuovi basamenti che donano al Cosmo un'immagine nuova e minimale.

Ma c'è anche un nuovo colore per presentarsi bello in ogni locale: al classico bianco della serigrafia del vetro si è aggiunta la variante nera, più elegante nei contesti metropolitani e nelle attività commerciali legate al Food & Beverage.

Ritroviamo Cosmo nella sua versione " + green", realizzata con il gas R290, che garantisce una sensibile riduzione delle emissioni di agenti inquinanti nell'aria, rappresentando sicuramente un prodotto molto più sostenibile rispetto al passato.

Cosmo meets the needs of catering professionals for preserving and displaying products, without giving up the luxury of a stunning, cutting-edge design. The most important restyling innovation is the use of the new bases which bestow to Cosmo a new and minimalist style.

But there is also a new colour to make it look good in any venue: to the classic white of the glass screen printing is now joined also by the black version, more elegant in metropolitan contexts and in Food & Beverage venues.

Cosmo also features a " + green" version, made with R290 gas, which guarantees a considerable reduction in emissions of pollutants into the air, and is certainly a much more sustainable product than in the past.



## Esaltare il lavoro dei nostri clienti

Enhance the work of our clients

Grazie a un design studiato ad hoc, l'esposizione viene valorizzata al massimo, garantendo al tempo stesso un'ottimale conservazione di tutti i tipi di prodotti.

Stile, leggerezza, luminosità: ogni dettaglio di questa vetrina è studiato per soddisfare le esigenze ed esaltare il lavoro dei nostri clienti

Thanks to a customised design, the display feature is enhanced to the maximum, while ensuring optimal preservation of all types of products.

Style, lightness, brightness: every detail of this display case is designed to meet the needs and enhance the work of our clients.



## Must Have dei locali food

Must-have of food venues

08

Prodotto già ampiamente utilizzato in tutti gli hub di viaggio, dagli aeroporti alle stazioni di servizio, oggi Cosmo è un must non solo in gelateria o in pasticceria, ma in ogni tipo di locale dedicato al food. Nel corso degli ultimi anni è diventato un elemento imprescindibile per gli acquisti legati al take away e al delivery. Inoltre, la sua esposizione verticale aiuta a trasformare l'attesa all'interno del punto vendita in un'importante esperienza d'acquisto.

A product already widely used in all travel hubs, from airports to petrol stations, today Cosmo is a must-have not only in ice-cream parlours or pastry shops, but in all types of food venues. Over the last few years, it has been an indispensable element for take-away and delivery sales. In addition, its vertical display design helps to transform the waiting time in the shop into a pleasant shopping experience.



09





## Efficienza e tecnologia senza precedenti

Unprecedented efficiency  
and technology

L'evoluzione di questa vetrina verticale non passa soltanto dal design, ma anche dalla tecnologia.

Un nuovo quadro comandi, quasi invisibile agli occhi del cliente ma facilmente accessibile e utilizzabile per l'operatore, è stato inserito nella porta ed è diventato "touch", permettendo di gestire la temperatura dell'armadio, di controllare l'illuminazione e di modificare le impostazioni di conservazione con pochissime operazioni.

The development of this vertical display case is not only based on design, but also on technology.

A new control panel, almost invisible to the client's eyes but easily accessible and usable for the operator was included in the door featuring "touch screen" technology, allowing the temperature and lighting to be managed together with food preservation settings in just a few steps.



# 700

singolo/doppio

12

 BT  
-18°/-20°

 T+  
+4°/+6°

 T+S  
+4°/+6°

 T+V  
+4°/+6°

 NO FROST  
-20°/+5°



**Personalizzazione**  
Personalization

Bianco / White

Nero / Black

**Il cosmo 700 è disponibile nella versione singola in tutte le tecnologie in gamma.**

**La versione 700 DOPPIA è disponibile nelle tecnologie BT STATICO e NO FROST.**

Cosmo 700 is available in the single version (one door) in all the technologies in the range.

The Double 700 version is available only for the models STATIC LOW TEMPERATURE and NO FROST.

# 900

singolo/doppio

 BT  
-18°/-20°

 T+  
+4°/+6°

 T+S  
+4°/+6°

 T+V  
+4°/+6°

 NO FROST  
-20°/+5°



**Personalizzazione**  
Personalization

Bianco / White

Nero / Black

**Il cosmo 900 è disponibile nella versione singola in tutte le tecnologie in gamma.**

**La versione 900 DOPPIA è disponibile nelle tecnologie BT STATICO e NO FROST.**

Cosmo 900 is available in the single version (one door) in all the technologies in the range.

The Double 900 version is available only for the models STATIC LOW TEMPERATURE and NO FROST.



14

## Il miglior posto di sempre

The best place ever



Il Cosmo si espande e si fa in due. La versione singola viene affiancata da quella a doppia porta, rendendola un must per qualsiasi locale food. Un'accessibilità maggiore, Il Cosmo doppio diventa la soluzione ideale per ogni esercizio commerciale del F&B, per tutti i cibi e le bevande e per qualsiasi esigenza.

Ordine, armonia e bellezza: con Cosmo l'universo delle tue creazioni sarà il miglior posto di sempre.

Cosmo expands and becomes two. The single-door version is joined by the double-door version, making it a must for any food venue. Greater accessibility, the double Cosmo becomes the ideal solution for any F&B venue, for all food and beverages and for any requirement.

Order, harmony and beauty: with Cosmo the universe of your creations will be the best place ever.

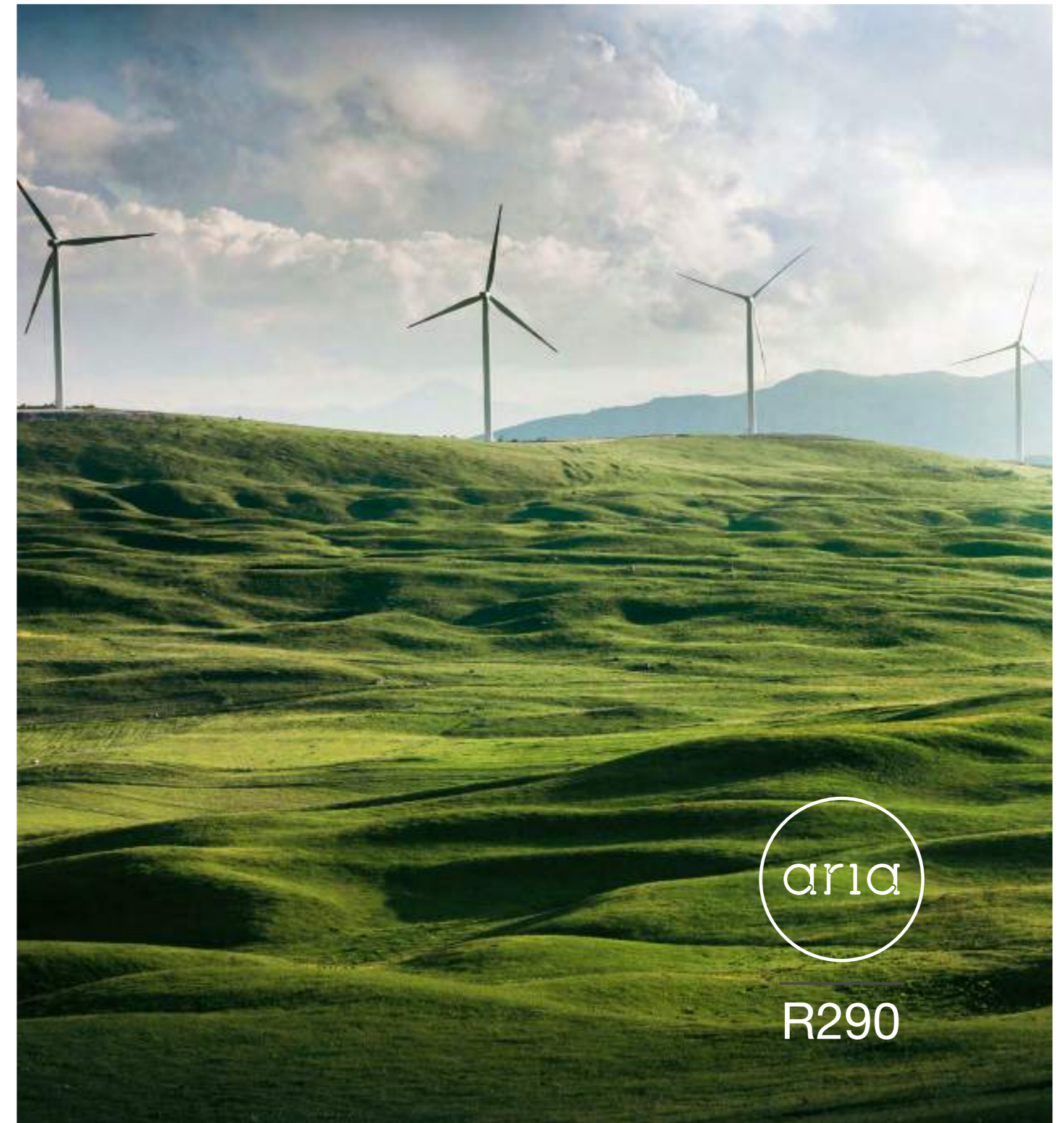

aria

R290



## Massima esperienza visiva

Maximum visual experience



Disponibile in diverse tecnologie del freddo e composizioni, Cosmo rappresenta come Orion intende l'armadio verticale: superfici trasparenti e il migliore sistema d'illuminazione per offrire ai clienti la massima esperienza visiva ed un'esposizione senza limiti.

Available in different refrigeration technologies and compositions, Cosmo represents how Orion interprets a vertical cabinet: transparent surfaces and the best lighting system to offer customers the maximum visual experience and unlimited display opportunities.

# COSMO

## 700

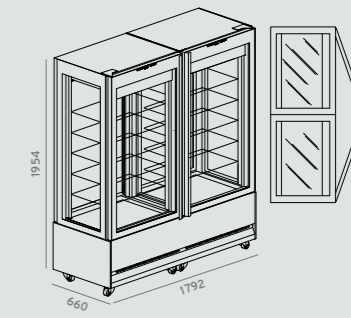
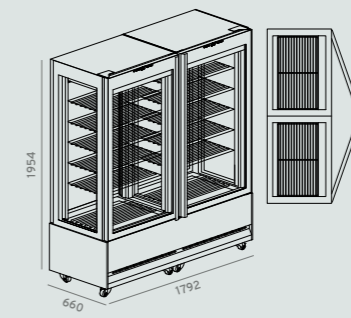
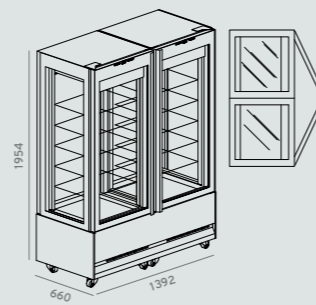
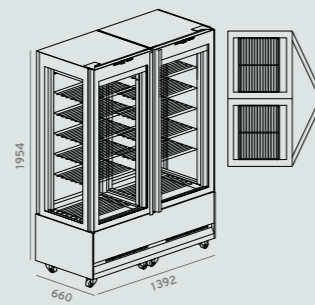
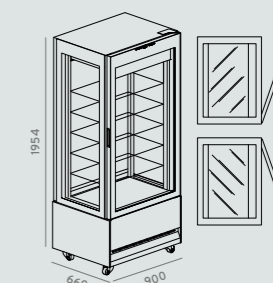
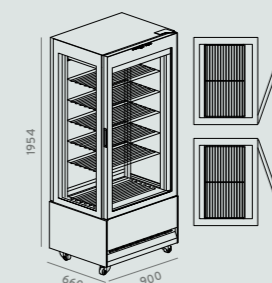
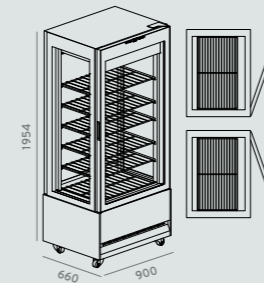
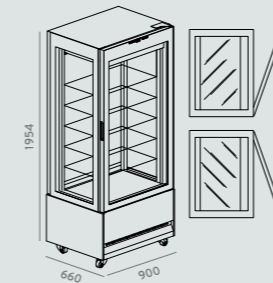
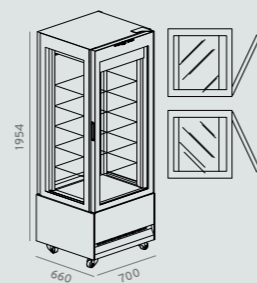
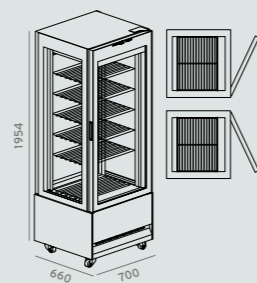
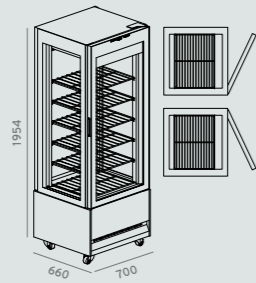
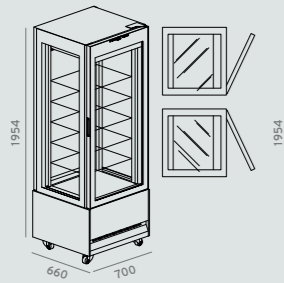

**T+S +4°/+6°**  
Temperatura  
Positiva Statica  
Static Positive temperature

- IMPIANTO DI REFRIGERAZIONE
- Unità refrigerante interna, con gas R290, condensazione ad aria.
  - Evaporatore statico a soffitto per il modello TN con sbrinatorio automatico.
  - Disponibile con n.6 mensole in vetro standard.

- REFRIGERATING SYSTEM
- In-built air-cooled condensing unit (R290 gas).
  - Static evaporator under roof for positive temperature model with automatic defrosting mode.
  - Available with N.6 glass shelves.



**T+V +4°/+6°**  
Temperatura  
Positiva Ventilata  
Ventilated Positive temperature

- IMPIANTO DI REFRIGERAZIONE:
- Unità refrigerante interna, con gas R290, condensazione ad aria.
  - Batteria evaporante fissata sotto il tettino con carter inferiore.
  - Disponibile con n.6 griglie, mensole in vetro optional.

- REFRIGERATING SYSTEM
- In-built air-cooled condensing unit (R290 Gas).
  - Evaporator placed under top roof equipped with lower guard.
  - Available with n. 6 grids (optional glass shelves)



**BT -18°/-20°**  
Temperatura  
Negativa Statica  
Static Positive temperature

- IMPIANTO DI REFRIGERAZIONE
- Unità refrigerante interna, con condensazione ad aria (R290 GAS).
  - Ripiani evaporanti statici fissi per il modello con sbrinatorio manuale.
  - Disponibile con n°5 ripiani evaporanti e n°5 ripiani in vetro

- REFRIGERATING SYSTEM
- In-built air-cooled condensing unit (R290).
  - Fixed static evaporating shelves for negative temperature model with manual defrosting mode.
  - Available with n.5 grids and glass shelves



**NO FROST -20°/+5°**  
Temperatura  
Positiva/ Negativa Ventilata  
No Frost version

- IMPIANTO DI REFRIGERAZIONE
- Unità refrigerante interna, con condensazione ad aria (Gas R290).
  - Batteria evaporante fissata sotto il tettino con carter inferiore.
  - Sbrinatorio automatico a gas caldo.
  - Disponibile con n°6 griglie e n°6 ripiani in vetro.

- REFRIGERATING SYSTEM
- In-built air-cooled condensing unit (R290 Gas).
  - Evaporator placed under top roof equipped with lower guard.
  - Automatic hot-gas defrosting in models.
  - Available with n.6 grids and glass shelves



**T+S +4°/+6°**  
Temperatura  
Positiva Statica  
Static Positive temperature

- IMPIANTO DI REFRIGERAZIONE:
- Unità refrigerante interna, con gas R290, condensazione ad aria.
  - Batteria evaporante fissata sotto il tettino con carter inferiore.
  - Disponibile con n.6 griglie, mensole in vetro optional.

- REFRIGERATING SYSTEM
- In-built air-cooled condensing unit (R290 Gas).
  - Evaporator placed under top roof equipped with lower guard.
  - Available with n. 6 grids (optional glass shelves)



**T+V +4°/+6°**  
Temperatura  
Positiva Ventilata  
Ventilated Positive temperature

- IMPIANTO DI REFRIGERAZIONE:
- Unità refrigerante interna, con gas R290, condensazione ad aria.
  - Batteria evaporante fissata sotto il tettino con carter inferiore.
  - Disponibile con n°5 ripiani evaporanti e n°5 ripiani in vetro

- REFRIGERATING SYSTEM
- In-built air-cooled condensing unit (R290 Gas).
  - Evaporator placed under top roof equipped with lower guard.
  - Available with n.5 grids and glass shelves (optional glass shelves)



**BT -18°/-20°**  
Temperatura  
Negativa Statica  
Static Positive temperature

- IMPIANTO DI REFRIGERAZIONE
- Unità refrigerante interna, con condensazione ad aria (R290 GAS).
  - Ripiani evaporanti statici fissi per il modello con sbrinatorio manuale.
  - Disponibile con n°5 ripiani evaporanti e n°5 ripiani in vetro

- REFRIGERATING SYSTEM
- In-built air-cooled condensing unit (R290).
  - Fixed static evaporating shelves for negative temperature model with manual defrosting mode.
  - Available with n.5 grids and glass shelves



**NO FROST -20°/+5°**  
Temperatura  
Positiva/ Negativa Ventilata  
No Frost version

- IMPIANTO DI REFRIGERAZIONE
- Unità refrigerante interna, con condensazione ad aria (Gas R290).
  - Batteria evaporante fissata sotto il tettino con carter inferiore.
  - Sbrinatorio automatico a gas caldo.
  - Disponibile con n°6 griglie e n°6 ripiani in vetro.

- REFRIGERATING SYSTEM
- In-built air-cooled condensing unit (R290 Gas).
  - Evaporator placed under top roof equipped with lower guard.
  - Automatic hot-gas defrosting in models. – Available with n.6 grids and glass shelves

*Orion si riserva il diritto di apportare modifiche ai prodotti illustrati in questo catalogo, in qualunque momento senza l'obbligo di preavviso.*

*Le finiture riprodotte in questo catalogo sono indicative per le inevitabili differenze dovute alla riproduzione tipografica.*

*Orion reserves the right to make modifications to the products shown in this catalogue at any time without prior notice. The finishings shown in this catalogue are approximate, as a printed reproduction causes inevitable colour differences.*

© ORION

*I prodotti possono essere tutelati da brevetto e/o da design. Tutti i diritti riservati*

*Products may be protected by patent and/or design. All rights reserved.*

EDIZIONE MARZO 2022

Hanno collaborato alla realizzazione di questo catalogo:

Art Direction/Graphic Design  
UP STUDIO  
Image  
STUDIO LEON  
3D Image  
STUDIO IMERGO  
Prepress  
MIC STUDIO  
Print  
GRAPHO 5 SERVICE

The logo for ORION, featuring the word "ORION" in a bold, black, sans-serif font. A thick, black, curved line arches over the letters, starting under the 'O' and ending under the 'N', creating a stylized orbital or protective shape.

**ORION**

VIALE DELL'INDUSTRIA 15  
60035 JESI (AN)  
ITALY

PHONE: +39 0731 61531  
FAX: +39 0731 6153413

INFOWEB@ORIONSTYLE.COM  
WWW.ORIONSTYLE.COM

[www.orionstyle.com](http://www.orionstyle.com)

**ORION**

Thr3e

ORION



*Design*  
**Stramigioli**  
**Associati**

Thr3e rappresenta il prodotto con cui Orion chiude la presentazione delle vetrine dedicate alla conservazione dei prodotti alimentari.

Orion entra nel mercato del food retail con prodotti che non passano mai inosservati, soprattutto perché contraddistinti da un "family feeling" riconoscibile e unico.

Thr3e è il nuovo piccolo gioiello perfettamente adattabile a qualsiasi locale perché Compatto, Innovativo e Flessibile. Tecnologia smart per un'esposizione senza confronti, lasciando liberi i clienti di sfruttare al meglio gli spazi all'interno del proprio negozio grazie alle due versioni in gamma:

**Grab'n Go** per agevolare il libero servizio dei prodotti già incartati tra cui il cliente può scegliere.

**Service** per gli acquisti guidati dalle preziose indicazioni dell'operatore.

# Thr3e

Compatta, Innovativa  
e Flessibile.

**Thr3e la piccola grande  
vetrina di Orion.**

A compact, innovative  
and flexible showcase.

**Thr3e is our little big showcase by Orion.**

Thr3e is the product with which Orion closes the presentation of the showcases dedicated to preserving foods and food-related products.

Orion enters the food retail market with brand-new outstanding products, since they stand out for their one-of-a-kind and easily recognizable "family feeling".

Thr3e is our new little jewel which can perfectly adapt to each premise being it compact, innovative and flexible. It also boasts a smart technology to ensure an unprecedented exposure by enabling our clients to best use the internal space inside the premises thanks to the two versions included in the product range:

**Grab'n Go** fosters the free take-away of the wrapped products for the clients to choose.

**Service** to buy the suggested products according to the operator's suggestions.

## Libero servizio, con Stile.

A stylish free take-away.

02

Design minimale e distintivo, Thr3e si inserisce con stile tra i prodotti dedicati al libero servizio nei locali food.

Una vetrina compatta con una schiena completamente refrigerata, in cui i prodotti sono perfettamente conservati e visibili al consumatore che è libero di scegliere, prendere ed acquistare.

Thanks to its minimal and outstanding design, Thr3e is one of the stylish products dedicated to the free take-away to be found in the food-related premises.

It is a compact showcase with a completely refrigerated rear panel, in which the products can be perfectly preserved while remaining clearly visible for the customer to freely choose, take and purchase them.



03

Thr3e  
Grab'n Go

## Tecnologia a servizio della funzionalità.

Technology merging into functionality.



Ogni prodotto esposto nella versione Grab'n Go di Thr3e è perfettamente conservato, facilmente accessibile e ben visibile. Esposizione che diventa esaltazione, con un focus particolare a tutti gli acquisti che vengono fatti d'impulso.

Each product to be showcased in the Grab'Go version is perfectly preserved, to be easily accessed while keeping the products clearly visible. Showcasing the products means enhancing them particularly focusing on all the purchases to be impulsively made.



04



## Spazio alla flessibilità.

A new flexibility.

Due lunghezze disponibili nella versione Grab'n Go, da accostare in modo lineare per creare un'esposizione continua di prodotti all'interno del locale.

Libere di arredare spazi diversi in un unico ambiente, contenitori di prodotti diversi, ma funzionali perché visibili ed accessibili nello stesso modo.

The range includes two available lengths for the Grab'n Go version, to be matched in a linear way to create a continuous showcasing for the products to be served in the premise.

The customers can freely design their premises to create a one-of-a-kind atmosphere, in order to showcase various products without forgetting to design a functional premise to make the products visible and accessible.

## Raccontare un prodotto esponendolo.

How to describe and showcase a product.

06

Il consumatore è sempre più esigente, spesso distratto e immerso in acquisti phygital, tra il punto vendita e l'online. Imperativo per ogni punto vendita è conquistarlo, Thr3e assolve a questo compito perché adattabile a diverse tipologie di locali.

Refrigerazione ventilata, spalle in vetro camera, illuminazione led e visibilità senza confronti queste le caratteristiche che rendono Thr3e ideale per l'esposizione di un'ampia gamma di prodotti.

The consumer is becoming more and more demanding, is often distracted and busy in phygital purchases between the sales point and the online sales. Capturing the consumers' attention is essential for each sales point and Thr3e perfectly fulfils the expectations since it can adapt to various kinds of premises.

It boasts a ventilated refrigeration system, glass end side panels, LED lighting and a one-of-a-kind visibility: all these features make Thr3e the ideal showcase to showcase a wide range of products.



**CAFFETTERIE**  
COFFEE SHOP



**MERCATO DI QUARTIERE**  
NEIGHBORHOOD FOOD MARKET



**HUB DI VIAGGIO**  
TRAVEL HUB



**STAZIONI DI SERVIZIO**  
SERVICE STATION



## Servito e soddisfatto, grazie ad una visibilità estrema

An extreme visibility to serve and satisfy the customers.

08

Design minimale e distintivo, anche per la versione Service di Thr3e che permette all'operatore un servizio agevole al consumatore, che sceglie tra i prodotti esposti grazie ad un sistema di esposizione accogliente, in cui tutto è perfettamente visibile.

Una vetrina compatta con ampie superfici vetrate, che garantendo l'esaltazione dei prodotti esposti stimolano i sensi del consumatore.

Thanks to the minimal and outstanding design, also the Service version enables the operators to easily serve the consumers, who chooses among the showcased products thanks to a welcoming showcasing system marking all the products clearly visible.

It is a compact showcase with wide glass surfaces enhancing the showcased products while stimulating the consumers' senses to guide the consumers into an aware purchase.



09

Thr3e  
Service

## Accessibile e funzionale.

Accessibility and functionality.



Nell'arco della giornata l'operatore compie gesti e movimenti ripetitivi, Thr3e Service permette che questi possano essere svolti in modo consapevole, rendendo il servizio al cliente fluido, ma anche le operazioni di carico della vetrina sono altrettanto semplici e veloci.

A seconda del tipo di prodotto che viene esposto, l'addetto alla vendita ha la possibilità di allestire la vetrina in modo da rispondere alle esigenze più particolari, accedendo ai ripiani grazie a comode porte in vetro camera che scorrono su ruote con chiusura assistita.

During the day the operator carries out repetitive gestures and movements, Thr3e Service enables the operator to carry them out being aware of their meaning while making the service fluid and the showcases' loading operations easier and faster.

According to the type of product to showcase, the sales operator can design the windows as to satisfy all the particular expectations, in order to access the tops thanks to the comfortable glass doors sliding on wheels with assisted closure.

## Compatta, ma di Design.

A compact and designed showcase.

10

Le linee pulite del frontale esaltano il design estremamente moderno e sofisticato della versione Service di Thr3e. La particolare sagomatura delle spalle terminali, le linee morbide del frontale rappresentano i must di questa proposta compatta dedicata al mondo del food retail.

L'equilibrio di componenti, volumi e proporzioni permette l'accostamento dei moduli creando linee espositive modulabili che arredano lo spazio con soluzioni innovative.

The clear front shapes enhance the extremely modern and sophisticated design for the Service version. The peculiar shape of the end side panels and the soft front shapes are the essential features of this compact showcase dedicated to the food retail world.

The balance among the components, volumes and proportions enable the clients to match the modules while creating modular shapes which design the space with innovative solutions.



## Esaltare i prodotti esposti.

Enhancing the showcased products.

Chi sceglie Thr3e Service sa di poter presentare e conservare nel modo migliore i prodotti caratteristici del mondo del food retail.

Visibilità estrema al servizio di una capienza senza paragoni, garantendo una tecnologia che rispecchia le performance conosciute ed apprezzate da sempre dai nostri clienti.

The clients who choose Thr3e Service know they can best present and preserve their typical products in the food retail field

Thanks to its extreme visibility ensuring the unprecedented widest capacity, this showcase ensures a technology reflecting the already known performances which have always been appreciated by our customers.



**PASTICCERIE**  
PASTRY SHOP



**CAFFETTERIE**  
COFFEE SHOP



**MERCATO DI QUARTIERE**  
NEIGHBORHOOD FOOD MARKET



**HUB DI VIAGGIO**  
TRAVEL HUB



# Gamma

Range

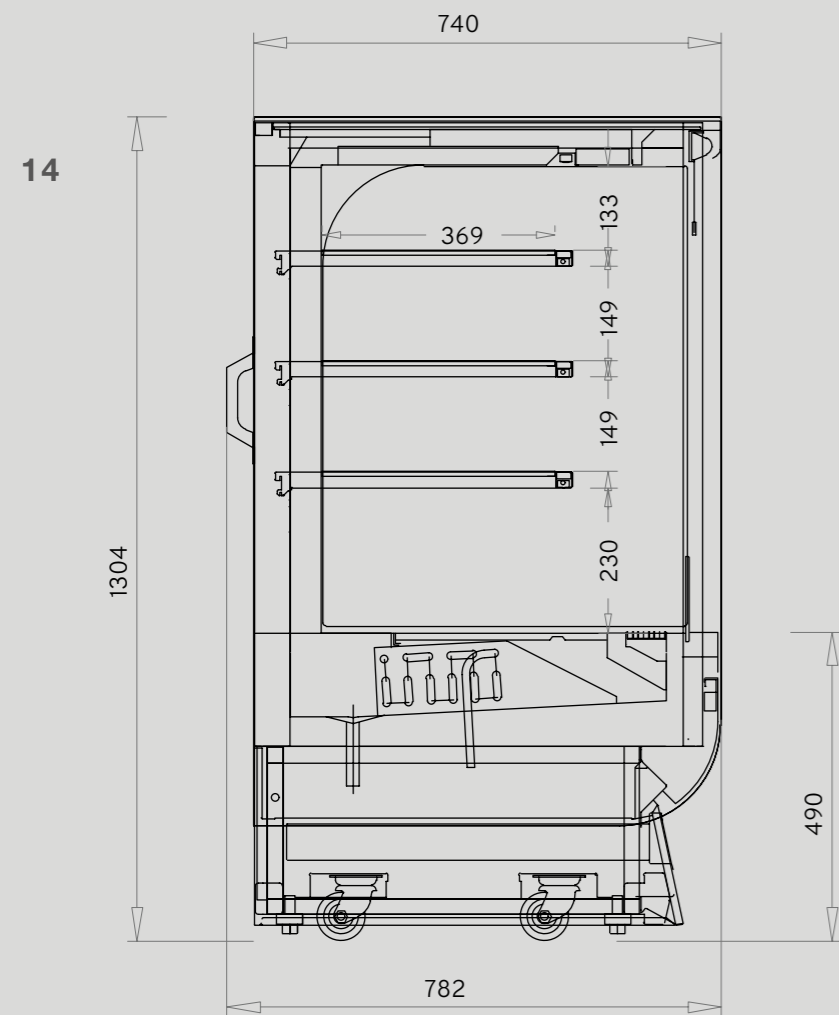

## THR3E GRAB'N GO T+ V +2°/+4° Temperatura Positiva Ventilata

VENTILATED POSITIVE TEMPERATURE

Vetrina Tr3e VERSIONE GRAB'N GO con refrigerazione ventilata. Unità interna ad Aria, illuminazione led sul tettino e mensole. Spalle terminali in vetro camera Con serigrafia RAL 7022. Rivestimento frontale, zoccolo frontale e laterale vano motore INCLUSI. personalizzabili RAL 9005 o RAL 9010, altri colori RAL optional. Zoccolo Laterale vano motore RAL 7022. Maniglie sul retro e ruote per la movimentazione. Tendina notte per la chiusura del vano espositivo.

Showcase Tr3e VERSIONE GRAB'N GO with a ventilated refrigeration system. Internal air-cooled unit, LED lighting on the top glass and on the shelves. Glass end side panels with a serigraphy painted in RAL 7022. Front covering, front and side plinth for the engine compartment included. To be customized as RAL 9005 or RAL 9010, other RAL colours are optional. Side plinth for the engine compartment in RAL 7022. Rear handles and movable wheels. Night curtain for closing the showcasing compartment.

### MODULI MODULES

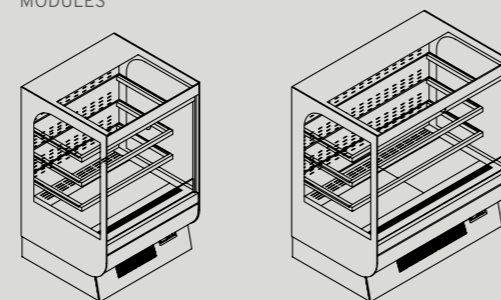

L. 900

L. 1200

### PIANTE DRAWINGS

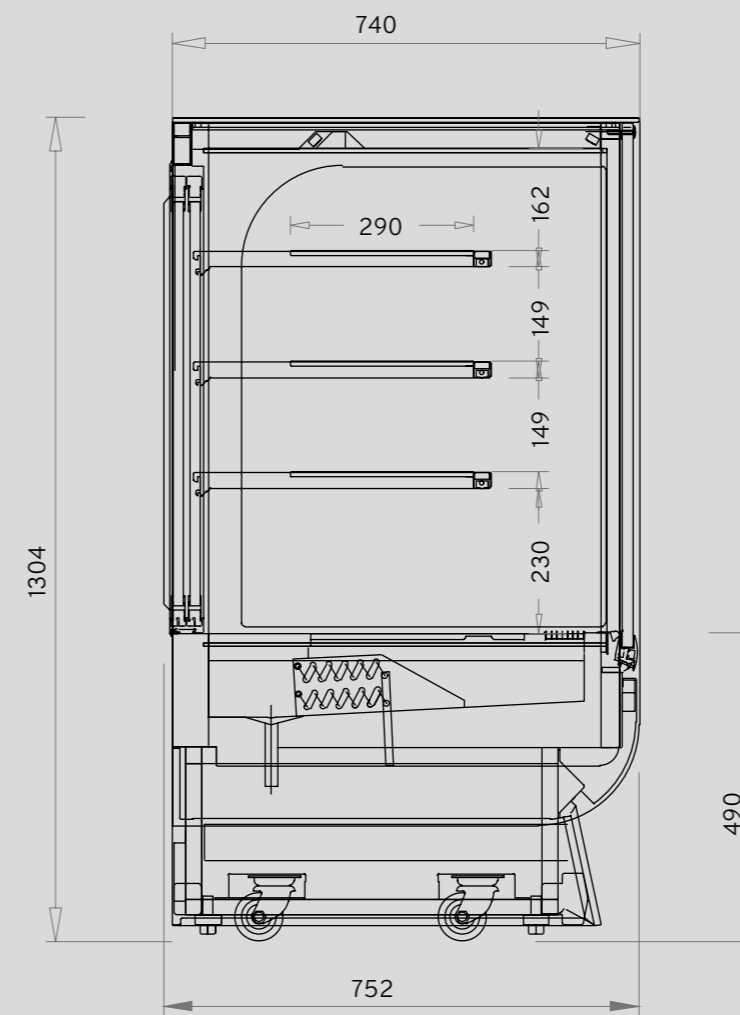
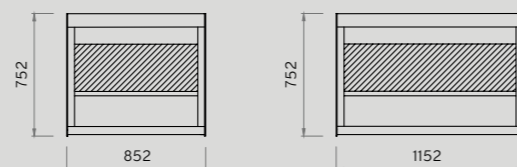

## THR3E SERVICE T+ V +4°/+8° Temperatura Positiva Ventilata

VENTILATED POSITIVE TEMPERATURE

Vetrina Tr3e VERSIONE SERVICE con refrigerazione ventilata. Unità interna ad Aria, illuminazione led sul tettino e mensole. Spalle terminali in vetro camera Con serigrafia RAL 7022. Accesso all'area espositiva tramite porte in vetro camera scorrevoli, chiusura assistita con cerniera. Rivestimento frontale, zoccolo frontale e laterale vano motore INCLUSI. Personalizzabili RAL 9005 o RAL 9010, altri colori RAL optional. Zoccolo Laterale vano motore RAL 7022. Ruote per la movimentazione.

Showcase Tr3e VERSIONE SERVICE with a ventilated refrigeration system. Internal air-cooled unit, LED lighting on the top glass and on the shelves. Glass end side panels with serigraphy in RAL 7022. The showcase compartment is accessible through sliding glass doors with assisted closure by means of a hinge. Front covering, front and side plinth for the engine compartment included. To be customized as RAL 9005 or RAL 9010, other RAL colours are optional. Front plinth for the engine compartment RAL 7022. Movable wheels.

### MODULI MODULES

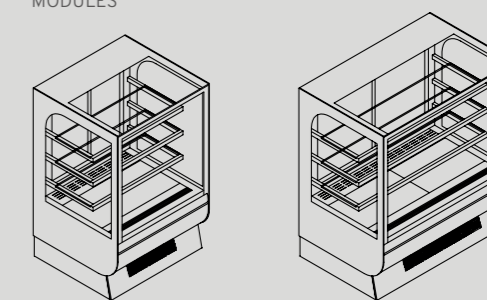

L. 900

L. 1200

### PIANTE DRAWINGS

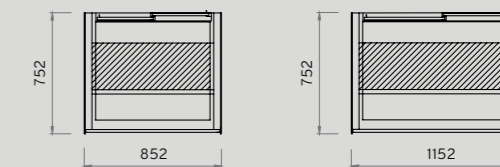

*Orion si riserva il diritto di apportare modifiche ai prodotti illustrati in questo catalogo, in qualunque momento senza l'obbligo di preavviso.  
Le finiture riprodotte in questo catalogo sono indicative per le inevitabili differenze dovute alla riproduzione tipografica.*

*Orion reserves the right to make modifications to the products shown in this catalogue at any time without prior notice.  
The finishings shown in this catalogue are approximate, as a printed reproduction causes inevitable colour differences.*

© ORION

*I prodotti possono essere tutelati da brevetto e/o da design.  
Tutti i diritti riservati*

*Products may be protected by patent and/or design.  
All rights reserved.*

**ORION**

ORION  
VIALE DELL'INDUSTRIA 15  
60035 JESI (AN)  
ITALY

PHONE: +39 0731 61531  
FAX: +39 0731 6153413

INFO@ORIONSTYLE.COM  
WWW.ORIONSTYLE.COM

EDIZIONE OTTOBRE 2021

Hanno collaborato  
alla realizzazione  
di questo catalogo:

Art Direction/Graphic Design  
UP STUDIO  
Prepress  
MIC STUDIO  
Print  
GRAPHO 5



[www.orionstyle.com](http://www.orionstyle.com)

**ORION**



B L U E

RIPRENDIAMOCI IL LUSO



BLUE  
INFINITO  
DI SPAZIO.  
BLUE  
IMMENSO  
DI MOTIVI.

INFINITE  
BLUE  
OF SPACE.  
IMMENSE  
BLUE  
IDEAS.

**ORLON**

02





BLUE versione  
BT/SINGOLO.  
Parti personalizzabili  
RAL 8029.  
Maniglie (Pos. 01).  
con inserti in legno.  
Negative temperature/single  
door version BLUE.  
Customisable parts  
in RAL 8029.  
Handle (Pos. 01).  
with wooden insert.

BLUE  
il manifesto  
del nuovo lusso:  
riappropriarsi  
di spazi, tempo  
ed emozioni.

BLUE,  
the manifesto  
for a brand  
new luxury:  
taking back space,  
time and emotion.



06



07

BLUE versione  
T+/SINGOLO.  
Parti personalizzabili  
RAL 8029.  
Maniglie (Pos. 01)  
con inserti in legno.  
Positive temperature/single  
door version BLUE.  
Customisable parts  
in RAL 8029.  
Handle (Pos. 01)  
with wooden insert.



Esplorare  
possibilità  
di esposizione  
continua fra  
i diversi moduli  
BLUE:  
nuovi spazi.

New spaces:  
you can  
experience  
the possibility  
of a continuous  
display between  
the blue modules.

08



BLUE versione  
T+/DOPPIO.  
Parti personalizzabili  
RAL 7048.  
Maniglie (Pos. 02)  
con inserti in legno.  
Positive temperature/double  
door version BLUE.  
Customisable parts  
RAL 7048.  
Handle (Pos.02)  
with wooden insert.

09



**PROGETTA IL TUO SPAZIO**

Design your place

Blue trova il suo spazio definito all'interno del locale, perfettamente inserito nel contesto in cui lavora. Blue consente INFINITE possibilità di posizionamenti in spazi da progettare.

Blue always finds its own space within the room, perfectly integrated into the context in which it works. You can place it wherever you want because it gives you endless possibilities of design.

10



Nell'immagine sopra: composizione di tre coppie di BLUE T+, inserite in un perimetro creato appositamente.

In the picture above you can see a composition of three couples of BLUE T+ showcases in a customized site.

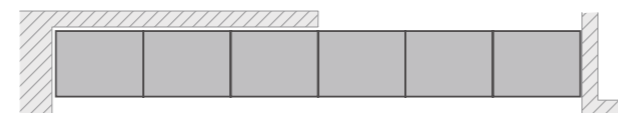

BLUE usato come le divisioni tipiche delle pareti mobili. Leggerezza e trasparenza del vetro per dividere ed unire allo stesso tempo.

This layout created using BLUE is based on the typical divisions of movable walls. Light, transparent glass is used to divide and bring together at the same time.



Un concept architettonico che permette di delimitare ambienti diversi, pur conservando un forte senso di unità complessiva, grazie alla massima trasparenza.

This idea for a layout using blue creates an architectural concept that makes it possible to divide a room into different areas, while still maintaining a strong sense of unity overall, thanks to the transparent glass doors.



Grande versatilità progettuale, l'armadio refrigerato diventa elemento architettonico del locale.

Maximum design versatility achievable with BLUE. The refrigerated cabinet becomes an architectural feature of the premises

12



BLUE versione  
T+/SINGOLO  
canalizzato con vetro  
di separazione interno.  
Parti personalizzabili  
ANOFOR ARC 2006.  
Maniglia (Pos. 01)  
con inserto in legno  
Positive temperature/single  
door canalized version  
BLUE with internal glass.  
Customisable parts  
in ANOFOR ARC 2006.  
Handle (Pos. 01)  
with wooden insert.

L'immagine  
del locale  
che diventa  
vetrina:  
bellezza  
per gli occhi  
che anticipa  
il gusto  
per il palato.

Shop design  
that becomes  
a showcase:  
a feast for  
the eyes that  
anticipates  
the feast  
for the taste.  
buds.

13







14

Puntare su pochi elementi che diano valore all'ambiente che li circonda.

Focus on just a few elements that give that basic design feel to their surroundings.



16



17

BLUE versione  
VINO/MODULO DOPPIO.  
Parti personalizzabili  
ANOFOR ARC 2006.  
Maniglie (Pos.02)  
con inserto laccato  
RAL 5020.  
Positive temperature/double  
door version BLUE  
for wine. Customisable  
parts in ANOFOR  
ARC 2006. Handle (Pos. 02)  
with laqued RAL 5020 insert.



**GAMMA E DIMENSIONI**  
Range and dimensions

18

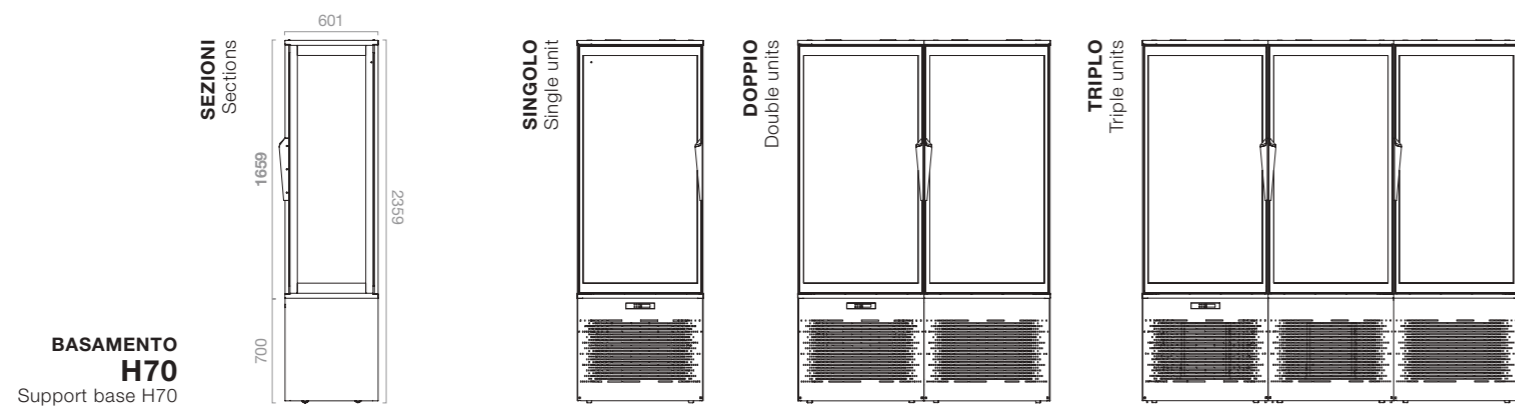
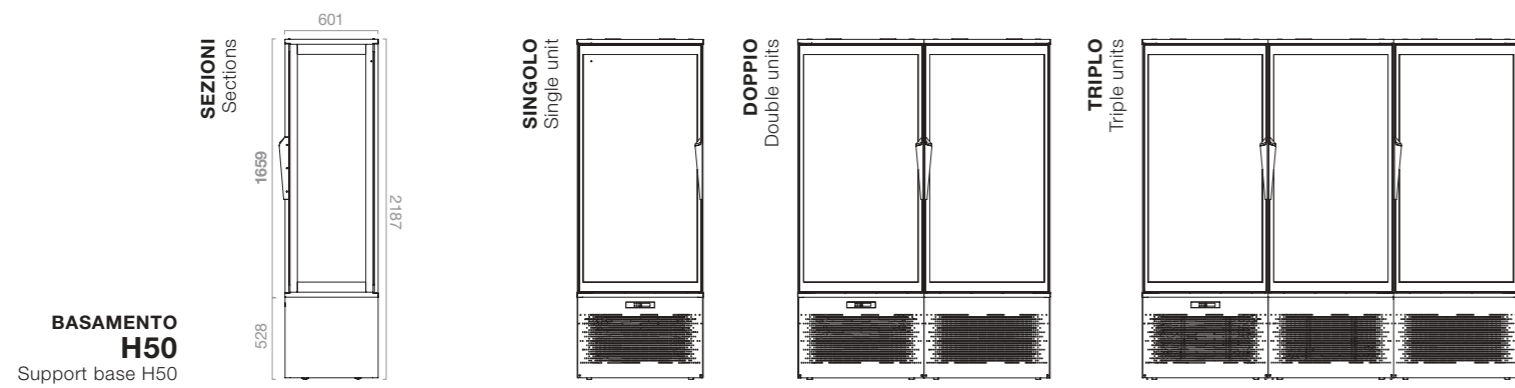
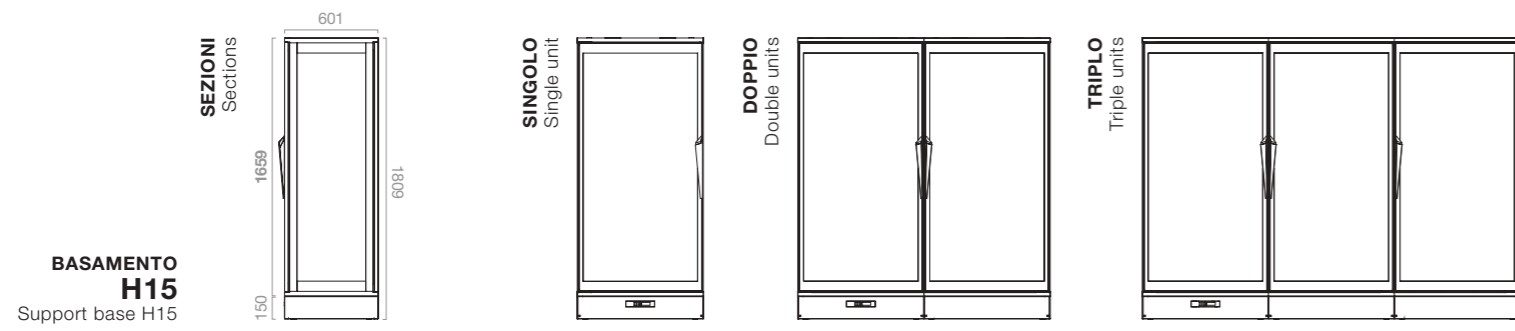

**T+ (+2°/+16°)**  
Positive version

**BT (-2°/-20°)**  
Negative version

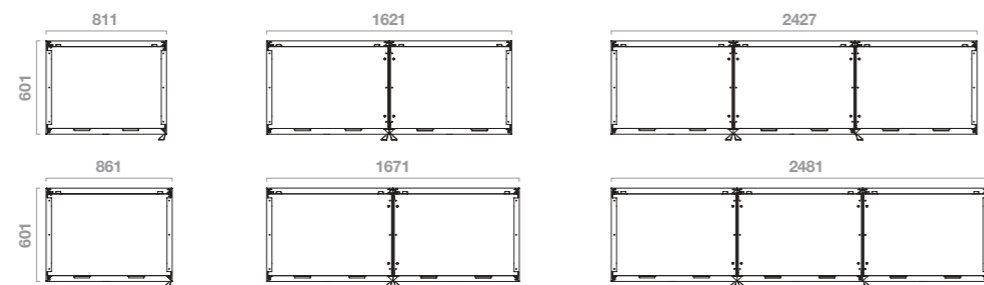

**TECNOLOGIE DISPONIBILI**  
Available technologies



**T+**  
(Positive temperature)  
**+2° / +8°**



**T+ CHOCO**  
(Positive temperature for praline)  
**+14° / +16° controlled umidity**



**BT**  
(Negative temperature)  
**-2° / -20°**



**T+ /WINE**  
(Positive temperature for wine)  
**+4° / +12°**



22



23

Nuovi spessori  
e ritrovata leggerezza  
per la struttura  
della porta:  
vetrina che abbatte  
le barriere e le rende  
parte del prodotto  
stesso.

New thicknesses  
and rediscovered  
lightness for the door,  
breaking down barriers  
and making them an  
invisible part of the  
product itself.



24



**BASAMENTO 50**

Il basamento del BLUE diventa "mobile" nelle varie versioni vano a giorno, cassetto neutro.  
(Disponibili solo nella versione con UR esterna)

**SUPPORT BASE, 50 CM HIGH.**

BLUE support base can be a customisable open compartment or a non refrigerated neutral drawer.  
(Only available with external cooling unit)



**BASAMENTO 70**

Il basamento del BLUE diventa "mobile" nelle varie versioni frigo bar, vano a giorno, cassetto neutro.  
(Disponibili solo nella versione con UR esterna)

**SUPPORT BASE, 70 CM HIGH.**

Blue support base can be a refrigerated counters, a customisable open compartment or a non refrigerated drawer.  
(Only available with external cooling unit)



26



BLUE versione  
BT/MODULO DOPPIO.  
Parti personalizzabili  
ANOFOR ARC 2006.  
Maniglie (Pos. 01)  
con inserto in legno.  
Negative temperature/double  
door version BLUE.  
Customisable parts  
in ANOFOR ARC 2006.  
Handle (Pos. 01)  
with wooden insert.

27



Unico nei dettagli  
personalizzabili.  
Il lusso è stimolazione  
delle percezioni.

Unique in detail  
customizable.  
Luxury is stimulation  
of perceptions.

28

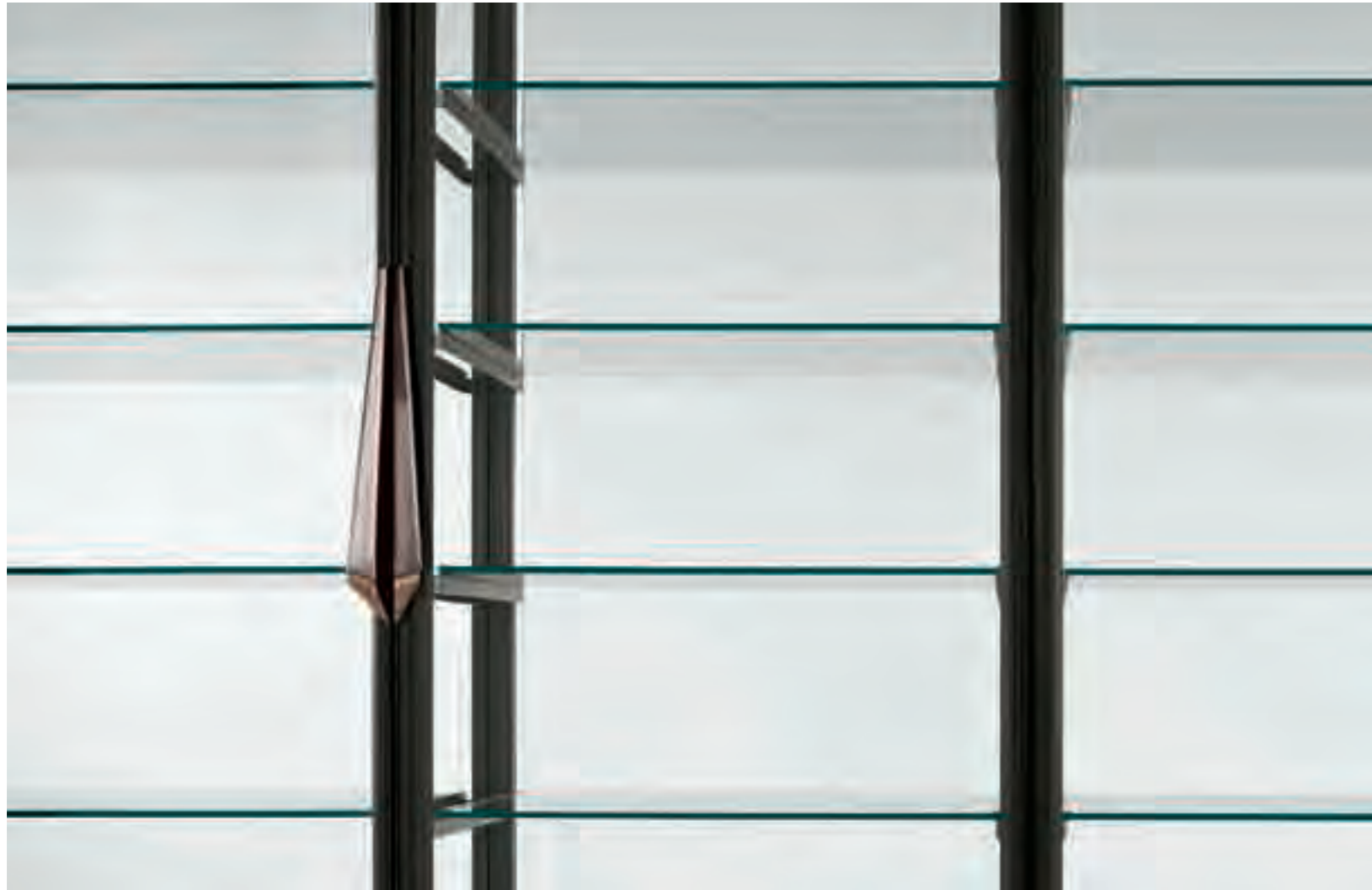



### ALTEZZE DA SCEGLIERE

Different heights



### BASAMENTO 15

**BASAMENTO CON ALTEZZA 15 CM.**

Disponibile solo nella versione con unità refrigerante esterna.

**SUPPORT BASE, 15 CM HIGH .**

Only available for the version with external cooling unit.



### BASAMENTO 50

**BASAMENTO CON ALTEZZA 50 CM  
PERSONALIZZABILE.**

Solo nella versione con motore esterno.

**SUPPORT BASE, 50 CM HIGH**

**CUSTOMISABLE SUPPORT BASE, 50 CM HIGH.**

Only available for the version with external cooling unit.



### BASAMENTO 70

**BASAMENTO CON ALTEZZA 70 CM  
PERSONALIZZABILE.**

Solo nella versione con motore esterno.

**SUPPORT BASE, 70 CM HIGH**

**CUSTOMISABLE SUPPORT BASE, 70 CM HIGH.**

Only available for the version with external cooling unit.



32

Il lusso si fa  
completamente  
tuo: si adatta  
ai bisogni,  
ai desideri,  
alle passioni.

Make luxury  
yours: adapt it  
to suite your  
needs, your  
desires and  
your passions.



Dettali che creano lusso, accessibili a tutti.

Details that create luxury, accessible to all.

34

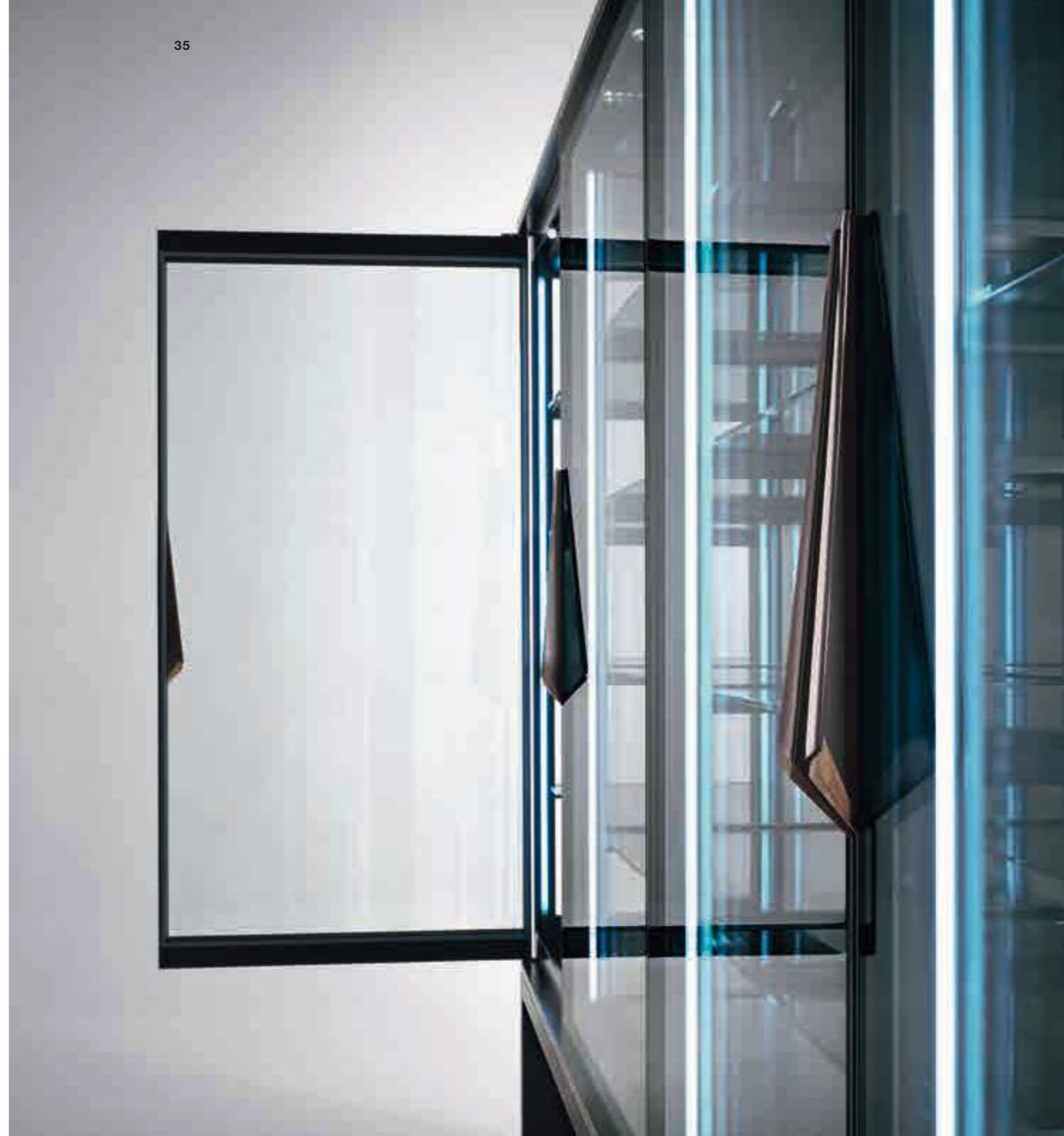

EDIZIONE DICEMBRE 2018

Hanno collaborato  
alla realizzazione  
di questo catalogo:

Art Direction  
STRAMIGIOLI ASSOCIATI  
Concept / Graphic Design  
UP STUDIO  
Image  
LIFE  
Prepress  
MIC STUDIO  
Print  
GRAPHO 5 SERVICE

**ORION**

**ORION**  
VIALE DELL'INDUSTRIA 15  
60035 JESI (AN)  
ITALY

PHONE: +39 0731 61531  
FAX: +39 0731 6153413

INFOWEB@ORIONSTYLE.COM  
WWW.ORIONSTYLE.COM



[www.orionstyle.com](http://www.orionstyle.com)

**ORION**

Se7en

ORION



# Se7en

**Generalista,  
mai generico.**  
Se7en, il nuovo  
murale refrigerato.

Multipurpose, but adaptable.  
Se7en: the new wall standing  
refrigerated showcase.

*Design  
Stramigioli  
Associati*

Design, Accessibilità/Easy Access,  
Modularità/Endless, Esposizione/Everywher,  
Conservazione/Everything, Customizzazione  
e Tecnologia/Energy Saving.  
Sono sette le caratteristiche del nuovo  
verticale refrigerato della famiglia dei  
verticali Orion, pensato e realizzato  
per soddisfare le esigenze di esposizione  
di tutto il mondo food: Se7en.

Non solo pasticceria e prodotti bakery,  
ma anche latticini, frutta e verdura,  
carni e bevande.

Grazie a Se7en, Orion entra nel mercato  
della refrigerazione e della conservazione  
del food, con un occhio di riguardo - quello  
che da sempre ci contraddistingue - al design,  
oltre che alla funzionalità.

Design, Accessibility, Modularity, Showcasing  
and Maintenance opportunities (Everywhere  
and Everything), Customization opportunities  
and functionality: these are the seven features  
of the new vertical refrigerated showcase  
promoted by Orion, being designed and  
produced to meet the needs of the  
food-related branch. This is Se7en.

You can preserve not only pastry and bakery  
products, but also dairy products, fruit  
and vegetables, meat and beverages.

Thanks to Se7en, Orion participates in the  
food-related refrigeration and preserving  
market, always boasting and standing out  
for its design and functionality.

**Prodigio di design,  
capolavoro di accessibilità:**  
ogni prodotto è visibile,  
non esiste gerarchia in un sistema  
di esposizione come Se7en che mette  
l'estetica e la funzionalità sullo stesso piano.

04

Perfect model in terms of design, masterpiece in terms of accessibility:  
every product is visible, there is no hierarchy in this showcasing system  
as in Se7en where aesthetics and functionality go hand in hand.



05



Hai mai provato a considerare la verticalità  
da un altro punto di vista?

Per la prima volta Orion crea un armadio a  
schiena completamente refrigerata, un prodotto  
che stimola i sensi del consumatore grazie ad un  
tipo di esposizione completamente accessibile.

Have you ever tried to consider the vertical  
structure from another point of view?

For the first time Orion has designed a vertical  
showcase with the supporting structure being  
completely refrigerated thus stimulating  
the clients' senses thanks to a completely  
accessible showcasing.





## Endless

Una gamma composta da quattro lunghezze, canalizzabili tra loro e che permettono un'esposizione senza confini per una totale adattabilità alle diverse tipologie di ambienti. La temperatura positiva ventilata si adatta ai diversi cibi da conservare attraverso optional dedicati, che permettono di cambiare configurazione ed ospitare differenti categorie di prodotto.

A range of models includes four lengths, which can be multiplexed and enable a showcasing without borders. The positive temperature ventilated version can be adapted to various foods by means of dedicated optionals which enable you to change the configuration and store various kinds of food.



**Se7en is everywhere,**  
perché valorizza ogni genere di locale.

08

Se7en is everywhere, since it enhances every premise.

Il mondo del food è in continua evoluzione, e Orion si fa trovare pronto. Piccola distribuzione, negozi di prossimità, stazioni di servizio, aeroporti, caffetterie di grandi e piccole catene: per affrontare le nuove richieste del mercato serve un prodotto altamente tecnologico, ma al tempo stesso modulare per una totale adattabilità alle diverse tipologie di locali.

The food-related branch is changing and Orion is ready. Retailers, local shops, service stations, airports, coffee shops of smaller and wider chains: In order to meet the new needs of the market we need a highly technological product which at the same time boasts modular structures – so that it can be completely adapted to various kinds of premises.



**STAZIONI DI SERVIZIO**  
Service Station



**HUB DI VIAGGIO**  
Travel Hub



**CAFFETTERIA**  
Coffee Shop



**BOTTEGA**  
Deli Shops



**MERCATO DI QUARTIERE**  
Neighborhood Food Market



**SANDWICH SHOP**  
Sandwich Shop



**RISTORANTE**  
Restaurant



**SUSHI SHOP**  
Sushi Shops

**Se7en is everything, perché contiene e dà visibilità a diverse tipologie di prodotti. Scegli quotidianamente un prodotto diverso da vendere, Se7en lo conserverà per te.**

**10** Se7en is everything, since it can store various products while making them visible. Choose the products to be sold daily, Se7en will preserve it for you.

**LATTICINI**

Dairy products



Yogurt



Panna



Burro



Latte



Bibite fresche a base di latte

**FRUTTA VERDURA**

Fruit & Vegetables



Frutta



Verdura

**CARNE**

Meat



Carne confezionata



Salumi

**PASTICCERIA**

Pastry



Lievitati



Torte



Dolci confezionati

**PANE**

Bakery products



Pizza



Pane



Sandwich

**BIBITE**

Drinks



Acqua



Birra



Lattine

# Personalizzazione

Customization opportunities

12

Immagina il Se7en che vuoi e poi realizzalo. Immagina di personalizzare il Se7en a seconda dei prodotti esposti e poi realizzalo. Immagina uno spazio espositivo che si adatti al tuo locale e poi realizzalo, con Se7en puoi. Scopri le combinazioni possibili tra cui scegliere per dar vita ad un prodotto che rappresenti la tua esposizione.

Figure out the Se7ev you wish and design it. Imagine you can customize your Se7en according to your showcased products and design it. Imagine a showcasing room to be adapted to your premise then design it: with Se7ven you can. Discover the available combinations to choose from to create a product fully representing your showcasing design.



## TETTINO RAL A SCELTA

Cieling lacquered

(Vedi prezzo e rivestimento / See finished version price)

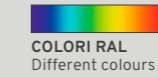

## INTERNI

Interiors

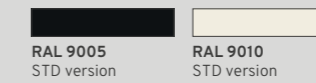

## MENSOLE INCLINABILI E REGOLABILI IN ALTEZZA

Tilting and height adjustable shelves

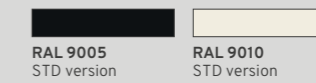

## RIVESTIMENTO FRONTALE RAL A SCELTA

Frontal panel

(Vedi prezzo e rivestimento / See finished version price)



## BASAMENTO RAL A SCELTA

Frontal panel

(Vedi prezzo e rivestimento / See finished version price)



## SPALLA IN VETROCAMERA

Double glazed end side panel

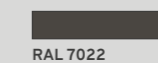

## Functionality

14

La prima volta di Orion con un armadio a schiena completamente refrigerata, un prodotto che stimola i sensi del consumatore grazie ad un tipo di esposizione completamente accessibile. Prodigio di design, capolavoro di accessibilità: tre diversi sistemi di apertura a disposizione del cliente, anche l'ergonomia ha un senso in Se7en che mette l'estetica e la funzionalità sullo stesso piano.

For the first time Orion has designed a vertical showcase with the supporting structure being completely refrigerated thus stimulating the clients' senses thanks to a completely accessible showcasing. Perfect model in terms of design, masterpiece in terms of accessibility: Se7en boasts three different opening systems at the clients' disposal. Ergonomics is a key aspect in Se7en where aesthetics and functionality go hand in hand.



**TENDA NOTTE**  
(versione standard)

Night curtain (standard version)



**PORTE BATTENTI**  
**IN VETROCAMERA**

double glazed doors



**SCORREVOLI**  
**IN VETROCAMERA**

double glazed sliding doors

## Gamma

### T+

**FREDDO VENTILATO**  
ventilated refrigeration

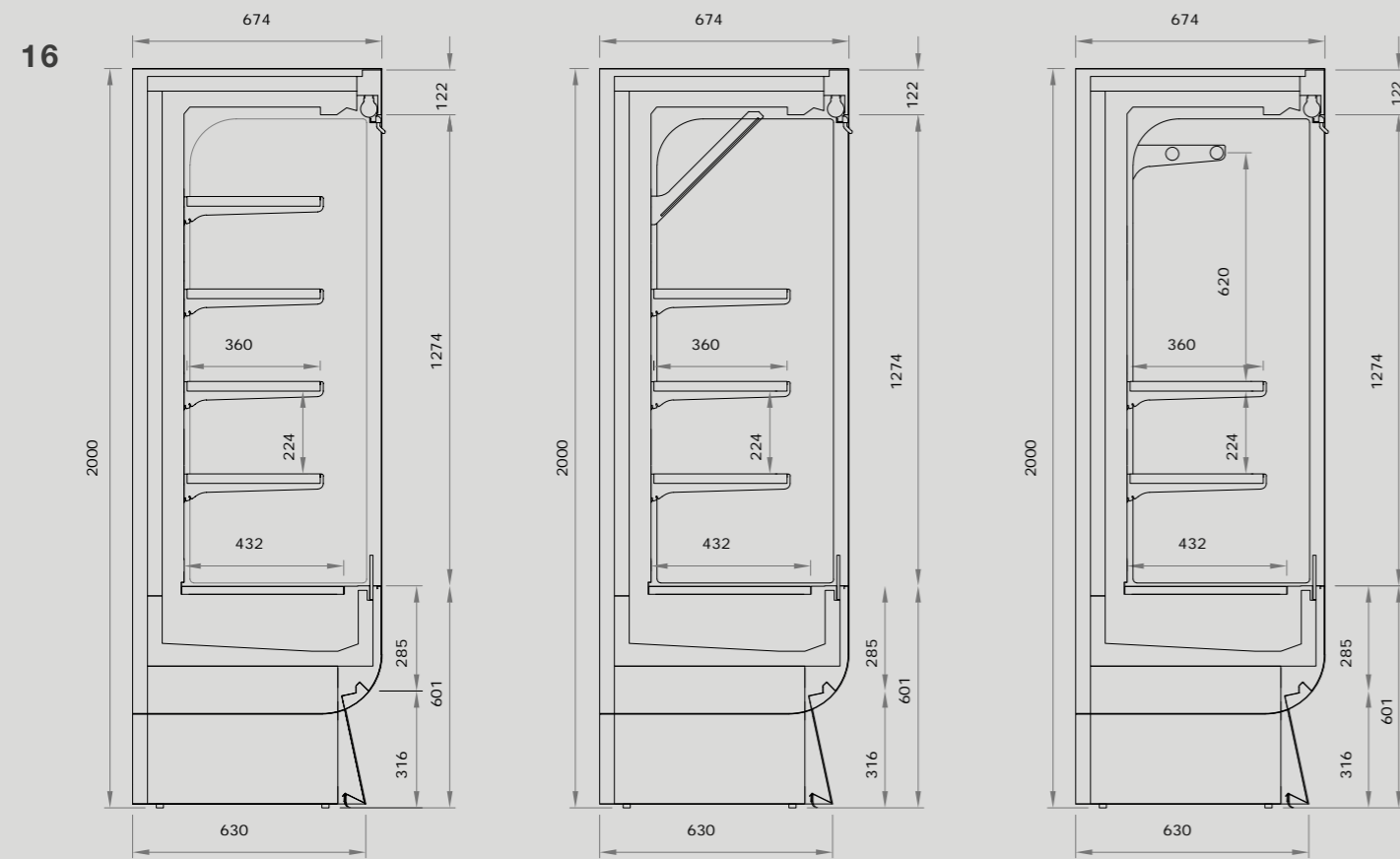

Murale Se7en Freddo ventilato con UR Interna.

**VERSIONE STANDARD**

Murale con spalle terminali, tenda notte di chiusura, n.4 ripiani interni regolabili in altezza e inclinabili ed illuminazione Led tettino.

**VERSIONE CON RIVESTIMENTO**

Pannello frontale di rivestimento e frontalino superiore, griglia frontale vano motore e zoccoli laterali vano motore, personalizzabili RAL, inclusi.

Se7en Wall Display unit ventilated refrigeration system with internal refrigerating unit.

**STANDARD VERSION**

End side panels, manual night curtain and height adjustable and tilted shelves, Led lighting on the top.

**FINISHED VERSION**

Front covering panel and upper front covering, front grid and side plinth for engine compartment, ral colour customizable.

## Dimensioni

Dimensions

L. 900

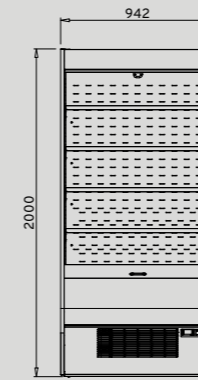

L. 1200

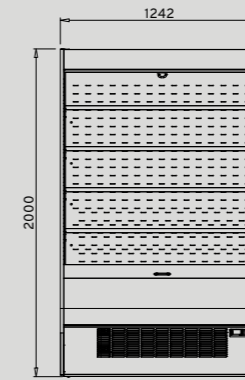

L. 1800

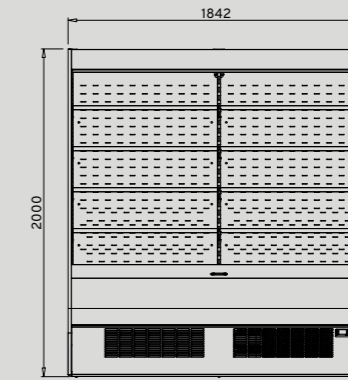

L. 2400

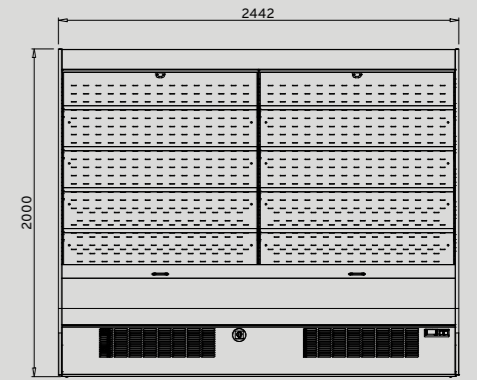

ASSONOMETRIA SEVEN singoli

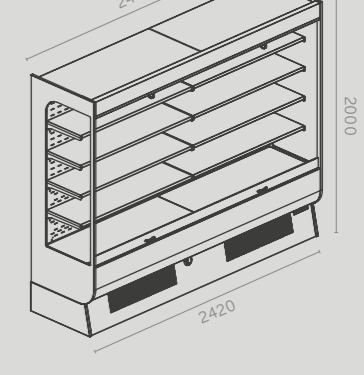
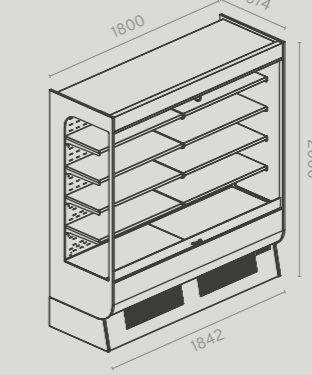
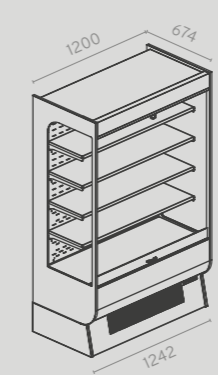
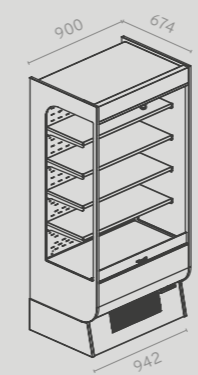

PIANTA SEVEN singoli

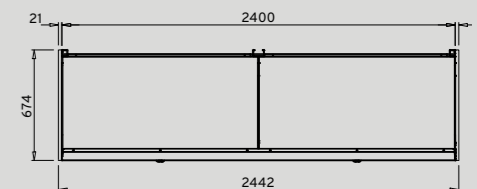
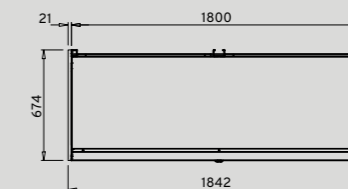
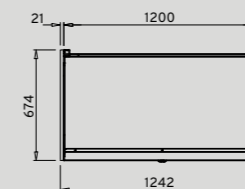
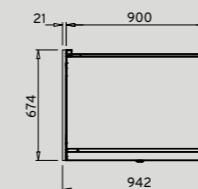

lato cliente

*Orion si riserva il diritto di apportare modifiche ai prodotti illustrati in questo catalogo, in qualunque momento senza l'obbligo di preavviso.  
Le finiture riprodotte in questo catalogo sono indicative per le inevitabili differenze dovute alla riproduzione tipografica.*

*Orion reserves the right to make modifications to the products shown in this catalogue at any time without prior notice.  
The finishings shown in this catalogue are approximate, as a printed reproduction causes inevitable colour differences.*

**© ORION**

*I prodotti possono essere tutelati da brevetto e/o da design.  
Tutti i diritti riservati*

*Products may be protected by patent and/or design.  
All rights reserved.*

EDIZIONE APRILE 2021

Hanno collaborato  
alla realizzazione  
di questo catalogo:

Art Direction/Graphic Design  
UP STUDIO  
Prepress  
STUDIO 59

**ORION**

**ORION**  
VIALE DELL'INDUSTRIA 15  
60035 JESI (AN)  
ITALY

PHONE: +39 0731 61531  
FAX: +39 0731 6153413

INFOWEB@ORIONSTYLE.COM  
WWW.ORIONSTYLE.COM

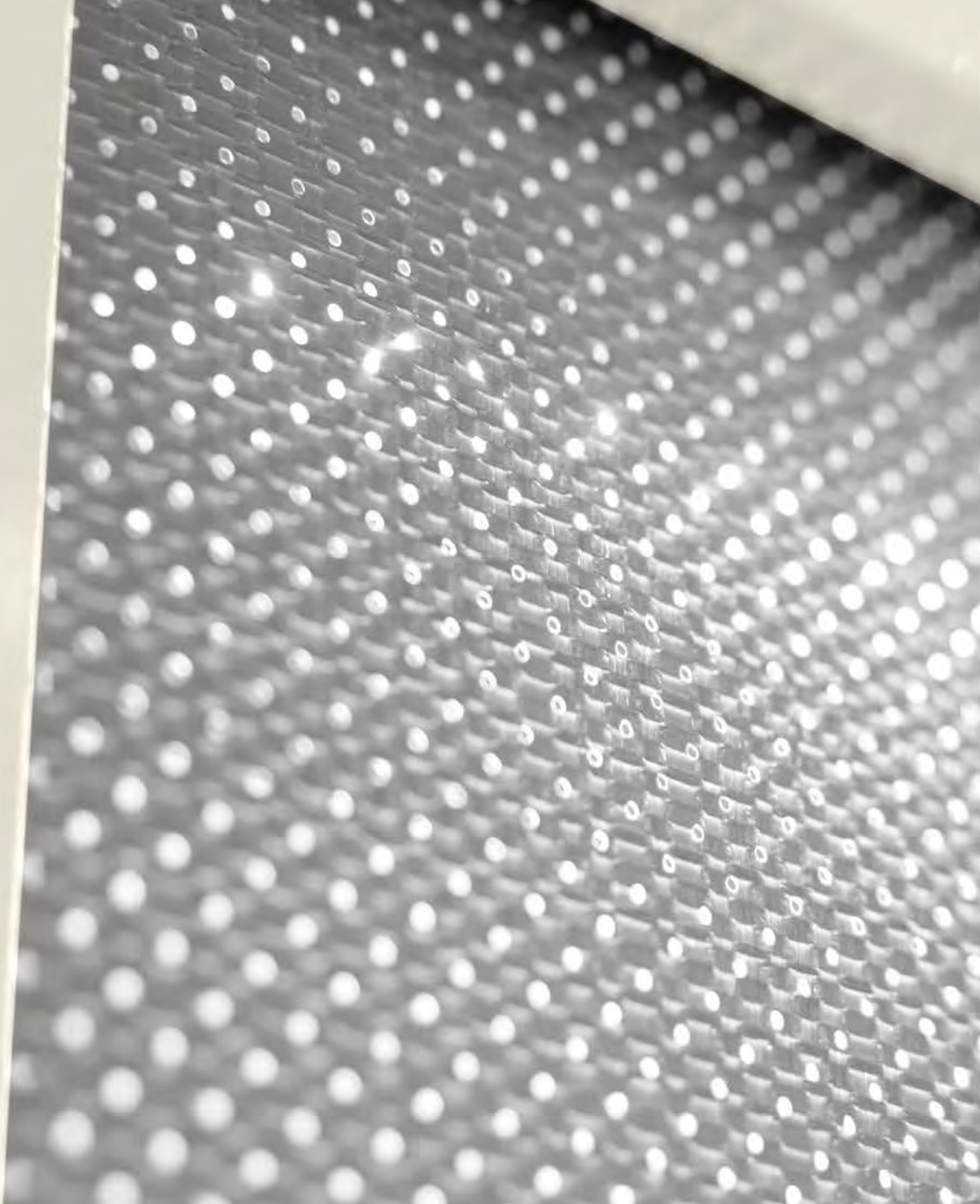

[www.orionstyle.com](http://www.orionstyle.com)

**ORION**



# WINE AND PASTRY DISPLAY CABINETS

*Vetrine vino e pasticceria*



**AROMA** pag. 290



**PST** pag. 292  
440/441 - 940 - 740/741  
Optionals & Accessories pag. 298



Our business is enhancing **your business**



AROMA

**Vetrine refrigerate statiche o ventilate per l'esposizione di vini spumanti, vini bianchi e vini rossi.**

- Colore standard: stile inox satinato
- Doppia illuminazione verticale a led
- Porta a basso emissivo, dotata di vetro panoramico per ampia visibilità
- Modelli con posizionamento bottiglie su tubi in acciaio (T) o su **ripiani inox forati (optional)**
- Solida maniglia in acciaio inox con serratura
- Controllo elettronico della temperatura posto nella parte superiore della vetrina.

**N.B.:** Per installazioni ad altitudini superiori a 900 m s.l.m., deve essere prevista e specificata al momento dell'ordine una valvola di compensazione per ogni vetrocamera.

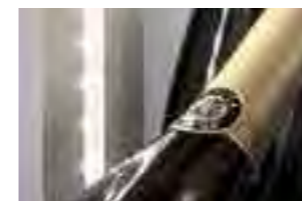

Doppia illuminazione a LED  
Double LED lighting



Tubi di appoggio bottiglie cromati  
Chromed support for bottles

**Static or ventilated wine display for all kind of sparkling, white or red wines.**

- Standard color: Brushed s/s style
- Double vertical LED lighting
- Door with reduced thermal losses, with large panoramic glass for wide visibility
- Models with bottles' positioning on stainless steel tubes (T) or **perforated stainless steel shelves (optional)**
- Sturdy s/s handle with lock
- Electronic control panel positioned in the upper part of the showcase.

**N.B.:** For installations at altitudes above 900 m (above sea level), a compensating valve for each double-glazing unit must be provided and specified at the time of the order.



Ripiani inox forati (optional)  
S/s shelves (optional)



Elegante maniglia in acciaio inox con serratura  
Elegant design s/s handle with lock

Modello Model	Codice Code	Prezzo € Price €	N° Bottiglie Nr Bottles ø77	Refrigerazione* Refrigeration*	Range Range (°C)	Gas Gas	Accessori** Accessories**	Dimensioni Dimensions (mm)	Assorbimento Absorbed power		Classe climatica Climate class	Alimentazione Power Supply (V/hz)	Dimensioni imballo Packing dimensions (mm)	Peso Netto/Lordo Net/Gross weight (kg)	
									Watt****	Ampere					
	<b>AROMA 610 S T</b>	6AROM610SA000	<b>4.250,00</b>	74	S	0/+7°	R290 GWP 3 Kg. 0,60	TUBI ACCIAIO S/S TUBES	610x515x1940	247	5.03	3 25°C - 60%	230/1/50	650x550xh2200	120/130
	<b>AROMA 610 V T</b>	6AROM610VA000	<b>4.400,00</b>	74	V	0/+7°		TUBI ACCIAIO S/S TUBES	610x515x1940	247	5.03	3 25°C - 60%	230/1/50	650x550xh2200	120/130
	<b>AROMA 820 S T</b>	6AROM820SA000	<b>4.650,00</b>	113	S	0/+7°	R290 GWP 3 Kg. 0,60	TUBI ACCIAIO S/S TUBES	820x515x1940	247	5.03	3 25°C - 60%	230/1/50	880x550xh2200	150/160
	<b>AROMA 820 V T</b>	6AROM820VA000	<b>4.800,00</b>	113	V	0/+7°		TUBI ACCIAIO S/S TUBES	820x515x1940	247	5.03	3 25°C - 60%	230/1/50	880x550xh2200	150/160
		72538296	<b>60,00</b>	Ripiano Inox forati (mod. AROMA 610)				Drilled s/s shelves (mod. AROMA 610)							
		72538294	<b>80,00</b>	Ripiano Inox forati (mod. AROMA 820)				Drilled s/s shelves (mod. AROMA 820)							
	<b>VERS220-1-60AROMA</b>	<b>252,00</b>	Sovraprezzo Versione 220V/1Ph/60Hz - GAS R404a (Disponibile non prima di 6 settimane)				Price increase for 220V/1Ph/60Hz Version - GAS R404a (Available not earlier than 6 weeks)								

\*S= STATICA / STATIC - V=VENTILATA / VENTILATED

\*\* T=TUBI ACCIAIO / S/S TUBES \*\*\*\* Watt TN (-10/+45°C)

I gas fluorati a effetto serra sono contenuti in apparecchiature ermeticamente sigillate.

Dati tecnici e caratteristiche soggetti a cambiamento senza preavviso.

Refrigerant gases are contained in hermetically sealed equipment

All specifications are subject to change without notice.



PST

440/441

PST



**Espositori refrigerati per pasticceria disponibili in versione sia statica che ventilata.**

- Temperature: -5° / +10°C, -22/+5°C (mod. ventilati); +2°/+10°C, -25°/-15°C (mod. statici)
- Tutti i modelli sono dotati di vetri sui 4 lati ed una porta
- Illuminazione LED
- Accessoriate con:  
griglie cromate (mod. V e S TN)  
griglie refrigeranti fisse (mod. S BT)  
o ripiani in vetro girevoli (mod. R)
- Su richiesta: versioni con 1, 2 o 3 lati ciechi, Griglie cromate aggiuntive, Ripiani vetro (in sostituzione alle griglie)

**Refrigerated display cabinets for pastry available with static or ventilated refrigeration system.**

- Temperature ranges: -5°/+10°C, -22/+5°C (ventilated mod.); +2°/+10°C, -25°/-15°C (static mod.)
- All models equipped with glasses on all 4 sides and one door
- LED lighting
- Internal fitting:  
chromed shelves (mod. V and S TN)  
refrigerated fixed shelves (Mod. S BT)  
glass rotating shelves (Mod. R)
- On request: versions with 1, 2 or 3 full sides, Additional chromed wired shelves, Glass shelves (instead of wired shelves)



Illuminazione a led  
LED lighting

	Modello Model	Codice Code	Prezzo € Price €	Capacità Capacity (Lt)	Refrigerazione* Refrigeration*	Range Range (°C)	Gas Gas	Ripiani Shelves	Dimensioni Dimensions (mm)	Assorbimento Absorbed power (W****)(A)	Voltaggio Voltage (Volt/Ph/ Hz)	Dimensioni imballo Packing dimensions (mm)	Peso Netto/ Lordo Net/Gross weight (kg)	MODELLO MODEL	USO CONSIGLIATO - SUGGESTED USE	
	PST440TNV	9PST440TNVN10	3.706,72	430	V	-5/+10	R290 GWP 3 Kg 0,12	5	670x640x1910	500	2,17	230/1/50	770x740x2200	164/184	PST440TNV PST441TNVR	VENTILATA POSITIVA: Bibite e vini (per stoccaggi elevati richiedere ripiani inox rinforzati)  POSITIVE FAN-ASSISTED: Drinks and wines (for high storage quantities, require reinforced s/s shelves)
	PST440TNS	9PST440TNSN10	3.329,66	450	S	+2/+10	R290 GWP 3 Kg 0,12	5	670x640x1880	400	1,74	230/1/50	770x740x2200	164/184	PST440BTV PST441BTVR	VENTILATA NEGATIVA: Prodotti gelateria, semifreddi, monoporzioni, cassate, sorbetti (Consigliato passaggio in abbattitore)  BELOW ZERO FAN-ASSISTED: Ice cream and semifreddo desserts, single-serving desserts, cassata, sorbets (blast chilling is suggested)
	PST440BTV	9PST440BTVN10	5.043,58	430	V	-22/+5	R290 GWP 3 Kg 0,15	5	670x640x1910	800	3,48	230/1/50	770x740x2200	166/186	PST440TNS PST441TNSR	STATICA POSITIVA: Pasticceria fresca di ogni tipo (no movimenti d'aria)  POSITIVE STATIC: All kind of fresh pastry products (no air movements)
	PST440BTS	9PST440BTSN10	3.946,69	450	S	-25/-15	R290 GWP 3 Kg 0,15	6 S	670x640x1880	750	3,26	230/1/50	770x740x2200	160/180	PST440BTS	STATICA NEGATIVA: Prodotti gelateria, torte e torte con panna, semifreddi, sorbetti, monoporzioni, profiterol, in conservazione per diversi giorni (Consigliato passaggio in abbattitore). Prodotti di pasticceria fresca congelata (Consigliato passaggio in abbattitore)  BELOW ZERO STATIC: Ice creams, cakes/cream cakes, semifreddo desserts, sorbets, single-serving desserts, profiterol, some days conservation (blast chilling is suggested). Frozen fresh pastry products (blast chilling is suggested)
	PST441TNVR	9PST441TNVR10	3.912,38	430	V R	-5/+10	R290 GWP 3 Kg 0,12	7 R	670x640x1930	500	2,17	230/1/50	770x740x2200	172/192	PST440BTS	BELOW ZERO STATIC: Ice creams, cakes/cream cakes, semifreddo desserts, sorbets, single-serving desserts, profiterol, some days conservation (blast chilling is suggested). Frozen fresh pastry products (blast chilling is suggested)
	PST441TNSR	9PST441TNSR10	3.448,93	450	S R	+2/+10	R290 GWP 3 Kg 0,12	7 R	670x640x1880	400	1,74	230/1/50	770x740x2200	170/192		
	PST441BTVR	9PST441BTVR10	5.454,91	430	V R	-22/+5	R290 GWP 3 Kg 0,15	7 R	670x640x1910	850	3,69	230/1/50	770x740x2200	175/195		
		RIP_IX_PST440	116,00	Ripiano forato inox per bottiglie							S/S shelf for bottles 510x420					

\*S= STATICA/STATIC - V= VENTILATA/VENTILATED - R= PIANI VETRO GIREVOLI/ROTATING GLASS SHELVES \*\*\*\* Watt TN (-10/+45°C)

I gas fluorurati a effetto serra sono contenuti in apparecchiature ermeticamente sigillate. Fluorinated greenhouse refrigerant gases are contained in hermetically sealed equipment.

Dati tecnici e caratteristiche soggetti a cambiamento senza preavviso. All specifications are subject to change without notice.



PST



PST

940

**Espositori refrigerati per pasticceria disponibili in versione sia statica che ventilata.**



- Temperature:  
-5° / +10°C, -22/+5°C (mod. ventilati)  
+2°/+10°C, -25°/-15°C (mod. statici)
- Tutti i modelli sono dotati di vetri sui 4 lati ed una porta
- Illuminazione LED
- Accessoriate con:  
griglie cromate (mod. V e S TN)  
griglie refrigeranti fisse (mod. S BT)  
cromate mobili (mod. V BT)
- Su richiesta: versioni con 1, 2 o 3 lati ciechi, Griglie cromate aggiuntive, Ripiani vetro (in sostituzione alle griglie)

**Refrigerated display cabinets for pastry available with static or ventilated refrigeration system.**

- Temperature ranges:  
-5°/+10°C, -22/+5°C (ventilated mod.)  
+2°/+10°C, -25°/-15°C (static mod.)
- All models equipped with glasses on all 4 sides and one door
- LED lighting
- Internal fitting:  
Chromed shelves (mod. V and S TN)  
refrigerated fixed shelves (Mod. S BT)  
movable chromed shelves (Mod. V BT)
- On request: versions with 1, 2 or 3 full sides, Additional chromed wired shelves, Glass shelves (instead of wired shelves)



Illuminazione a led  
LED lighting

Modello Model	Codice Code	Prezzo € Price €	Capacità Capacity (Lt)	Refrigerazione* Refrigeration*	Range Range (°C)	Gas Gas	Ripiani Shelves	Dimensioni Dimensions (mm)	Assorbimento Absorbed power (W****)(A)	Voltaggio Voltage (Volt/Ph/Hz)	Dimensioni imballo Packing dimensions (mm)	Peso Netto/ Lordo Net/Gross weight (kg)		
	<b>PST940TNV</b>	<b>9PST940TNVN10</b>	<b>5.192,00</b>	600	V	-5/+10	R290 GWP 3 Kg 0,12	5	900x640x1910	500	2,17	230/1/50	1000x740x2200	164/184
	<b>PST940TNS</b>	<b>9PST940TNSN10</b>	<b>4.688,00</b>	630	S	+2/+10	R290 GWP 3 Kg 0,12	5	900x640x1880	450	1,96	230/1/50	1000x740x2200	164/184
	<b>PST940BTV</b>	<b>9PST940BTVN10</b>	<b>6.764,00</b>	600	V	-22/+5	R452A GWP2141 Kg 0,60	5	900x640x1910	700	3,04	230/1/50	1000x740x2200	164/184
	<b>PST940BTS</b>	<b>9PST940BTSN10</b>	<b>5.984,00</b>	630	S	-25/-15	R452A GWP2141 Kg 0,60	6	900x640x1880	750	3,26	230/1/50	1000x740x2200	164/184

MODELLO MODEL	USO CONSIGLIATO - SUGGESTED USE
<b>PST940TNV</b>	VENTILATA POSITIVA: Bibite e vini (per stoccaggi elevati richiedere ripiani inox rinforzati) <i>POSITIVE FAN-ASSISTED (Electronic temperature control): Drinks and wines (for high storage quantities, require reinforced s/s shelves)</i>
<b>PST940TNS</b>	STATICA POSITIVA: Pasticceria fresca di ogni tipo (no movimenti d'aria) <i>POSITIVE STATIC: All kind of fresh pastry products (no air movements)</i>
<b>PST940BTV</b>	VENTILATA NEGATIVA: Prodotti gelateria, semifreddi, monoporzioni, cassate, sorbetti (Consigliato passaggio in abbattitore) <i>BELOW ZERO FAN-ASSISTED: Ice cream and semifreddo desserts, single-serving desserts, cassata, sorbets (blast chilling is suggested)</i>
<b>PST940BTS</b>	STATICA NEGATIVA: Prodotti gelateria, torte e torte con panna, semifreddi, sorbetti, monoporzioni, profiterrol, in conservazione per diversi giorni (Consigliato passaggio in abbattitore). Prodotti di pasticceria fresca congelata (Consigliato passaggio in abbattitore) <i>BELOW ZERO STATIC: Ice creams, cakes/cream cakes, semifreddo desserts, sorbets, single-serving desserts, profiterrol, some days conservation (blast chilling is suggested). Freezed fresh pastry products (blast chilling is suggested)</i>

\*S= STATICA/STATIC - V= VENTILATA/VENTILATED - R= PIANI VETRO GIREVOLI/ROTATING GLASS SHELVES \*\*\*\* Watt TN (-10/+45°C)

I gas fluorurati a effetto serra sono contenuti in apparecchiature ermeticamente sigillate. *Fluorinated greenhouse refrigerant gases are contained in hermetically sealed equipment.*

Dati tecnici e caratteristiche soggetti a cambiamento senza preavviso.

*All specifications are subject to change without notice.*

\*Modelli ventilati: controllo elettronico di temperatura; modelli statici: regolazione temperatura con termostato meccanico.

\*Fan assisted model: electronic temperature control; Static models: temperature control with mechanical thermostat.



PST

740/741

PST



**Espositori refrigerati per pasticceria disponibili in versione sia statica che ventilata.**

- Temperature:  
-5° / +10°C, -22/+5°C (mod. ventilati)  
+2°/+10°C, -25°/-15°C (mod. statici)
- Tutti i modelli sono dotati di vetri sui 4 lati e due porte
- Illuminazione LED
- Accessoriate con:  
griglie cromate (mod. V e S TN)  
griglie refrigeranti fisse (mod. S BT)  
o ripiani in vetro girevoli (mod. R)
- Su richiesta: versioni con 1, 2 o 3 lati ciechi, Griglie cromate aggiuntive, Ripiani vetro (in sostituzione alle griglie)



Illuminazione a led  
LED lighting

**Refrigerated display cabinets for pastry available with static or ventilated refrigeration system.**

- Temperature ranges:  
-5°/+10°C, -22/+5°C (ventilated mod.)
- +2°/+10°C, -25°/-15°C (static mod.)
- All models equipped with glasses on all 4 sides and two doors
- LED lighting
- Internal fitting:  
chromed shelves (mod. V and S TN)  
refrigerated fixed shelves (Mod. S BT)
- glass rotating shelves (Mod. R)
- On request: versions with 1, 2 or 3 full sides, Additional chromed wired shelves, Glass shelves (instead of wired shelves)

Modello Model	Codice Code	Prezzo € Price €	Capacità Capacity (Lt)	Refrigerazione* Refrigeration*	Range Range (°C)	Gas Gas	Ripiani Shelves	Dimensioni Dimensions (mm)	Assorbimento Absorbed power (W****)(A)	Voltaggio Voltage (Volt/Ph/ Hz)	Dimensioni imballo Packing dimensions (mm)	Peso Netto/ Lordo Net/Gross weight (kg)	
	<b>PST740TNV</b>	<b>9PST740TNVN10</b>	<b>6.083,42</b>	V	-5/+10	R290 GWP 3 Kg 0,15	8	1320x640x1910	680	2,96	230/1/50	1420x740x2200	255/275
	<b>PST740TNS</b>	<b>9PST740TNSN10</b>	<b>5.020,80</b>	S	+2/+10	R290 GWP 3 Kg 0,15	8	1320x640x1880	800	3,48	230/1/50	1420x740x2200	252/272
	<b>PST740BTV</b>	<b>9PST740BTVN10</b>	<b>7.625,95</b>	V	-22/+5	R452A GWP 2141 Kg 0,80	8	1320x1950x1910	1200	5,22	230/1/50	1420x740x2200	277/297
	<b>PST740BTS</b>	<b>9PST740BTSN10</b>	<b>6.529,06</b>	S	-25/-15	R452A GWP 2141 Kg 0,60	12 S	1320x640x1880	1200	5,22	230/1/50	1420x740x2200	262/282
	<b>PST741TNVR</b>	<b>9PST741TNVR10</b>	<b>6.426,21</b>	V R	-5/+10	R290 GWP 3 Kg 0,15	5 + 7 R	1320x640x1910	680	2,96	230/1/50	1420x740x2200	267/287
	<b>PST741TNSR</b>	<b>9PST741TNSR10</b>	<b>5.534,98</b>	S R	+2/+10	R290 GWP 3 Kg 0,15	5 + 7 R	1320x640x1880	800	3,48	230/1/50	1420x740x2200	271/291
	<b>PST741BTVR</b>	<b>9PST741BTVR10</b>	<b>8.654,30</b>	V R	-22/+5	R452A GWP2141 Kg 0,60	5 + 7 R	1320x640x1910	1200	5,22	230/1/50	1420x740x2200	248/268

MODELLO MODEL	USO CONSIGLIATO - SUGGESTED USE
<b>PST740TNV PST741TNVR</b>	VENTILATA POSITIVA: Bibite e vini (per stoccaggi elevati richiedere ripiani inox rinforzati) POSITIVE FAN-ASSISTED: Drinks and wines (for high storage quantities, require reinforced s/s shelves)
<b>PST740BTV PST741BTVR</b>	VENTILATA NEGATIVA: Prodotti gelateria, semifreddi, monoporzioni, cassate, sorbetti (Consigliato passaggio in abbattitore) BELOW ZERO FAN-ASSISTED: Ice cream and semifreddo desserts, single-serving desserts, cassata, sorbets (blast chilling is suggested)
<b>PST740TNS PST741TNSR</b>	STATICA POSITIVA: Pasticceria fresca di ogni tipo (no movimenti d'aria) POSITIVE STATIC: All kind of fresh pastry products (no air movements)
<b>PST740BTS</b>	STATICA NEGATIVA: Prodotti gelateria, torte e torte con panna, semifreddi, sorbetti, monoporzioni, profiterol, in conservazione per diversi giorni (Consigliato passaggio in abbattitore). Prodotti di pasticceria fresca congelata (Consigliato passaggio in abbattitore) BELOW ZERO STATIC: Ice creams, cakes/cream cakes, semifreddo desserts, sorbets, single-serving desserts, profiterol, some days conservation (blast chilling is suggested). Freezed fresh pastry products (blast chilling is suggested)

\*S= STATICA/STATIC - V= VENTILATA/VENTILATED - R= PIANI VETRO GIREVOLI/ROTATING GLASS SHELVES \*\*\*\* Watt TN (-10/+45°C)

I gas fluorurati a effetto serra sono contenuti in apparecchiature ermeticamente sigillate.

Fluorinated greenhouse refrigerant gases are contained in hermetically sealed equipment.

Dati tecnici e caratteristiche soggetti a cambiamento senza preavviso.

All specifications are subject to change without notice.

\*Modelli ventilati: controllo elettronico di temperatura; modelli statici: regolazione temperatura con termostato meccanico.  
\*Fan assisted model: electronic temperature control; Static models: temperature control with mechanical thermostat.

# E-LINE

Armadi per prodotti confezionati, tavoli, saladette, vetrine  
*Cabinets for packed food, counters, saladette, pan cooler*



**E-390** pag. 302  
**E800 / E1000** pag. 304



**E-SALADETTE / E-TAVXS**  
pag. 306



**E-VTR** pag. 308



Our business is enhancing **your business**







**Armadi refrigerati 390 TN/BT porta cieca, o porta vetro, in lamiera d'acciaio bianca anti-corrosione interna ed esterna per prodotti confezionati.**

- Evaporatore roll bond con ventilatore interno (mod.TN); refrigerazione statica (mod.BT)
- 5 griglie regolabili (mod. TN), 7 piani fissi evaporanti (mod. BT porta cieca), 6 ripiani fissi (mod. BT porta vetro)
- Termostato e piedini regolabili
- Guarnizione porta sostituibile
- Realizzato senza CFC
- Illuminazione interna
- Sbrinamento manuale TN e BT porta cieca, automatico TN e BT porta vetro.

**390 Single full door (PC) or glass door (PV), upright chillers (TN) and freezers (BT), made of white anti-corrosion s/s sheet, inside and outside for packaged food.**

- Roll bond evaporator with internal fan (mod.TN); static refrigeration (mod.BT)
- 5 adjustable shelves (mod.TN), 7 fixed evaporator shelves (mod.BT full doors), 6 fixed shelves (mod. BT glass door)
- Adjustable thermostat and feet
- Replaceable door gasket
- CFC free
- Interior light
- Manual defrost for full door, automatic for glass door models.

**E-LINE  
CABINETS  
E-390**

	Codice Code	Prezzo € Price €	Range Range °C	Gas Gas kg	Classe climatica Climate class °C - %	Consumo elettrico annuale Annual electricity consumption kWh		Volume utile netto Net storage volume L	Griglie N° Shelves Nr	Dimensioni Dimensions (mm)	Assorbimento Absorbed power Watt**** Ampere		Voltaggio Voltage (Volt/Ph/Hz)	Dimensioni imballo Packing dimensions (mm)	Peso Netto/Lordo Net/Gross weight (Kg)
	<b>E-390TN</b>	<b>1.225,00</b>	+1° / +12°C	R600A Kg 0,080	4 (30°C - 55%)	2.1		270	5 (dim. 495x360mm)	595x630x1830	225	1,96	230/1/50	620x680x1967	64/70
	<b>E-390TNV</b>	<b>1.235,00</b>	+1° / +12°C	R600A Kg 0,080	4 (30°C - 55%)	3.4		270	5 (dim. 495x360mm)	595x670x1830	300	1,5	230/1/50	620x720x1967	66/72
	<b>E-390BT</b>	<b>1.668,00</b>	-12° / -22°C	R600A Kg 0,080	4 (30°C - 55%)	7.2		270	7 (Ripiani evaporanti / Freezing Shelves)	600x630x1870	610	3,3	230/1/50	625x680x2007	78/84
	<b>E-390BTV</b>	<b>2.029,00</b>	-15° / -20°C	R290 GWP 3 Kg 0,085	4 (30°C - 55%)	8.6		270	6 (Ripiani evaporanti / Freezing Shelves)	600x630x1870	720	4,5	230/1/50	625x680x2007	93/99

I gas fluorurati a effetto serra sono contenuti in apparecchiature ermeticamente sigillate.  
Dati tecnici e caratteristiche soggetti a cambiamento senza preavviso.

Refrigerant gases are contained in hermetically sealed equipment.  
All specifications are subject to change without notice.





**E-LINE  
CABINETS**  
E-800 E-1000

**Armadi refrigerati per bibite 800 TN e 1000 TN, in lamiera d'acciaio bianca trattata anti-corrosione interna ed esterna.**

- 2 Porte a vetro scorrevoli
- Pannello frontale luminoso posizionato sopra le porte
- Ruote per maggiore facilità di spostamento
- Serratura ed illuminazione interna LED di serie
- Vetro di sicurezza temperato
- Sistema digitale di controllo di temperatura
- Sistemi indipendenti di accensione per luce pannello frontale ed interna
- Refrigerazione ventilata
- Sistema di sbrinamento automatico.

**800 and 1000 Double door upright drink cooler, made of white anti-corrosion steel sheet inside and outside.**

- 2 Glass sliding doors
- Top with advertising panel
- Castors for easy positioning
- Lock and internal LED light as standard
- Toughened safety glass
- Digital temperature control
- Independent switch for canopy and internal light
- Fan assisted cooling
- Automatic defrost system.

	Codice Code	Prezzo € Price €	Range Range °C	Gas Gas kg	Classe climatica Climate class °C - %	Consumo elettrico annuale Annual electricity consumption kWh/annuo		Volume utile netto Net storage volume L	Griglie N° Shelves Nr	Dimensioni Dimensions (mm)	Assorbimento Absorbed power Watt**** Ampere	Voltaggio Voltage (Volt/Ph/Hz)	Dimensioni imballo Packing dimensions (mm)	Peso Netto/Lordo Net/Gross weight (Kg)
	E-800TNSN	2.451,00	+1° / +10°C	R290 GWP 3 Kg 0,120	4 (30°C - 55%)	6.5		800	8 (dim.445x480mm Ø 6.5mm)	1000x730x2035	480 3	230/1/50	1055x780x2175	146/162
	E-1000TNSN	2.709,00	+1° / +10°C	R290 GWP 3 Kg 0,120	4 (30°C - 55%)	6.55		1000	8 (dim.535x480 Ø 6.5mm)	1200x730x2038	480 3,4	230/1/50	1255x780x2175	159/192

I gas fluorurati a effetto serra sono contenuti in apparecchiature ermeticamente sigillate.  
Dati tecnici e caratteristiche soggetti a cambiamento senza preavviso.

Refrigerant gases are contained in hermetically sealed equipment  
All specifications are subject to change without notice.







## **Elegance is the only beauty that never fades.**

L'eleganza è l'unica  
bellezza che non  
svanisce mai.

A REFINED AND PERFORMING PIECE  
OF FURNITURE, AN ADDED VALUE FOR  
YOUR BUSINESS CRAFTED BY FRAMEC'S  
EXPERIENCE ON THE MARKET.

• • •

UN AUTENTICO VALORE AGGIUNTO PER  
IL LOCALE, UN ELEMENTO DI DESIGN,  
ELEGANTE E DALLE GRANDI PRESTAZIONI,  
DA SEMPRE FIRMA DISTINTIVA DI CASA  
FRAMEC.

# Refined lines to match any décor

Per ogni esigenza di arredo



AVAILABLE IN 3 VERSIONS

Disponibile in 3 versioni

-15° -22° C

STATIC NEGATIVE TEMPERATURE

A temperatura negativa statica

.....  
-2° +10° C

STATIC POSITIVE TEMPERATURE

A temperatura positiva statica

.....  
-22° +5° C

VENTILATED NEGATIVE TEMPERATURE

A temperatura negativa ventilata



MIRROR FINISH INTERIOR

Vasca interna in acciaio a specchio



THANKS TO ITS REFINED DESIGN, AVAILABLE IN TWO COLORS, VENERE IS THE IDEAL MATCH FOR ANY INTERIOR DECORATION.

• • •

GRAZIE AL SUO DESIGN RAFFINATO DISPONIBILE IN 2 COLORAZIONI, VENERE SI SPOSA PERFETTAMENTE CON QUALSIASI STILE D'ARREDO.



## Venere

Vetrine espositive positive/negative 3 lati vetrati  
3 side upright glass display coolers/freezers



TEMPERATURE RANGE

-22° +10° C

IDEAL FOR





## CARATTERISTICHE TECNICHE - TECHNICAL FEATURES

	VENERE PSB/W	VENERE NSB/W	VENERE NVB/W
Temperatura - Temperature	-2°C +10°C	-15°C -22°C	+5°C -22°C
Gas refrigerante - Refrigerant gas	R290	R290	R290
Classe climatica - Climate Class	4 (30°C-55%RH) H2	4 (30°C-55%RH) L1	4 (30°C-55%RH) L1
Dimensioni (L x p x h) - Sizes (w x d x h)	668 x 781 x 2000 mm	668 x 773 x 2000 mm	668 x 781 x 2000 mm
Peso netto - Net weight	142 kg	147 kg	142 kg
Peso lordo - Gross weight	156 kg	161 kg	156 kg
Volume Netto - Net volume	317 l	317 l	317 l
Volume Lordo - Gross volume	470 l	470 l	470 l
Potenza - Power	370 W	520 W	640 W
Consumo - Consumption	3,51 kWh/24h	6,4 kWh/24h	8,47 kWh/24h
Dimensioni imballo (L x p x h) - Packaging sizes (w x d x h)	745 x 775 x 2133 mm	745 x 775 x 2133 mm	745 x 775 x 2133 mm
Dati per il trasporto - Transport data (20 ft - 40 ft - 40 hc - 13,60 mt)	21/48/48/51	21/48/48/51	21/48/48/51
Ripiani - Shelves	5 rimovibili / removable	6 fissi / fixed	5 rimovibili / removable + 1 fondo vasca / bottom tank
Classe energetica - Energy efficiency class			

- ✓ **Ideale per ogni tipo di prodotto da pasticceria e gelateria**  
Ideal for any kind of product from pastry to ice-cream shop
- ✓ **3 Ampi lati vetrati per una massima visibilità**  
3 Wide side glasses for maximum visibility

- ✓ **Interno a specchio per esaltare il prodotto esposto**  
Mirror finish interior to highlight the displayed product
- ✓ **Rispetto ambientale: Gas R290**  
Environmentally friendly: R290 Gas



## APPROFONDIMENTO - MORE DETAILS

### Evaporatore statico con tubo in rame e alette in alluminio con resistenze di sbrinamento (mod. PS)

Static evaporator, copper tube (finned) with antifrost heaters (mod. PS)

### Evaporatore ventilato con tubo in rame e alette in alluminio con resistenze di sbrinamento (mod. NV)

Ventilated evaporator, copper tube (finned) with antifrost heaters (mod. NV)

### Evaporatore statico a griglie fisse con cattura brina (mod. NS)

Static evaporator, with fixed shelves and catch frost (mod. NS)

### Vasca interna in lamiera d'acciaio inox AISI 304

AISI 304 stainless steel sheet cabinet

### Termostato-termometro elettronico con sbrinamento manuale (mod. NS)

Electronic thermostat-thermometer with manual defrosting (mod. NS)

### Termostato-termometro elettronico con sbrinamento automatico (mod. PS-NV)

Electronic thermostat-thermometer with automatic defrosting (mod. PS-NV)

### Vetro porta: vetrata isolante (3 vetri) spessore 42 mm, cornice della vetrata serigrafata basso emissivo magnetronico con film anti-appannante

Glass door: insulating glass 42 mm (3 glasses) frame glass silkscreened low emission magnetron with anti fog film

### 2x Luce interna verticale a LED

2x Vertical internal LED light

**DI SERIE: 4 rullini unidirezionali + 2 piedi regolabili + serratura**  
AS STANDARD: 4 one-way wheels + 2 adjustable feet + lock



## ACCESSORI - ACCESSORIES

Cod.	Optional	Modelli - Models
0621422	Griglia plastificata - Plasticized shelf	VENERE PS - NV
340110000100	Supporto con piolo (4 per griglia) - Hook (4 for each shelf)	VENERE PS - NV
8808189	Kit 5 ripiani in vetro - 5 Glass shelves kit	VENERE PS - NV
8808190	Kit 6 ripiani in vetro - 5 Glass shelves kit	VENERE NS
2601090	Cestello per gelato confezionato - Basket for packaged ice cream	VENERE NS



## Venere BS

Vetrina verticale negativa

Glass door upright display freezer



TEMPERATURE RANGE

-22° +5° C

IDEAL FOR



**CARATTERISTICHE TECNICHE - TECHNICAL FEATURES**

<b>VENERE NVBSG</b>	
Temperatura - <i>Temperature</i>	+5°C -22°C
Gas refrigerante - <i>Refrigerant gas</i>	R290
Classe climatica - <i>Climate Class</i>	4 (30°C-55%RH) L1
Dimensioni (L x p x h) - <i>Sizes (w x d x h)</i>	668 x 781 x 2000 mm
Peso netto - <i>Net weight</i>	142 kg
Peso lordo - <i>Gross weight</i>	156 kg
Volume Netto - <i>Net volume</i>	317 l
Volume Lordo - <i>Gross volume</i>	470 l
Potenza - <i>Power</i>	640 W
Consumo - <i>Consumption</i>	6,44 kWh/24h
Dimensioni imballo (L x p x h) - <i>Packaging sizes (w x d x h)</i>	745 x 775 x 2133 mm
Dati per il trasporto - <i>Transport data (20 ft - 40 ft - 40 hc - 13,60 mt)</i>	21/48/48/51
Ripiani - <i>Shelves</i>	5 rimovibili / removable + 1 fondo vasca / bottom tank
Classe energetica - <i>Energy efficiency class</i>	

✓ **Ideale per ogni tipo di prodotto da gelateria**  
Ideal for any kind of product for ice-cream shop

✓ **Interno a specchio per esaltare il prodotto esposto**  
Mirror finish interior to highlight displayed product

✓ **Porta totalmente vetrata**  
Fully glazed door

✓ **Mobile grigio glitter**  
Glitter grey body

✓ **Rispetto ambientale: Gas R290**  
Environmentally friendly: R290 Gas

**APPROFONDIMENTO - MORE DETAILS**

**Mobile in lamiera d'acciaio grigio glitter trattata anti corrosione**  
Glitter grey anti corrosion treated steel sheet cabinet

**Vasca interna in lamiera d'acciaio inox AISI 304**  
AISI 304 stainless steel sheet cabinet

**Evaporatore ventilato con tubo in rame e alette in alluminio con resistenze di sbrinamento**  
Ventilated evaporator, copper tube (finned) with antifrost heaters

**Vetro porta: vetrata isolante spessore 42 mm, cornice della vetrata serigrafata nera basso emissivo magnetronico con film antiappannante**

Glass door: insulating glass 42 mm frame glass silkscreened black low emission magnetronico with anti fog film

**2x Luce interna verticale a LED**  
2x Vertical internal LED light

**DI SERIE: 4 rullini unidirezionali + 2 piedi regolabili + serratura**  
AS STANDARD: 4 one-way wheels + 2 adjustable feet + lock

**ACCESSORI - ACCESSORIES**

Cod.	Optional	Modelli - <i>Models</i>
0621422	Griglia plastificata - <i>Plasticized shelf</i>	VENERE BS
3401100000100	Supporto con piolo (4 per griglia) - <i>Hook (4 for each shelf)</i>	VENERE BS





<b>Expo PT</b>	<b>50</b>
<b>Murales</b>	<b>52</b>
<b>Murales SD</b>	<b>54</b>
<b>Murales HD</b>	<b>56</b>
<b>Supersunny SD</b>	<b>58</b>
<b>Supersunny HD</b>	<b>60</b>
<b>Ska</b>	<b>62</b>
<b>Oasi A</b>	<b>64</b>
<b>Oasi M</b>	<b>66</b>
<b>Domino</b>	<b>68</b>



mondial



## Expo PT

Vetrina verticale positiva  
Glass door upright display cooler



TEMPERATURE RANGE

+2° +8° C

IDEAL FOR



**CARATTERISTICHE TECNICHE - Technical features**

	<b>EXPO 400 PT</b>
Temperatura - <i>Temperature</i>	+2°C +8°C
Gas refrigerante - <i>Refrigerant gas</i>	R290
Classe climatica - <i>Climate Class</i>	4 (30°C-55%RH) H1
Dimensioni (L x p x h) - <i>Sizes (w x d x h)</i>	668 x 685 x 1990 mm
Peso netto - <i>Net weight</i>	106 kg
Peso lordo - <i>Gross weight</i>	118 kg
Volume Netto - <i>Net volume</i>	353 l
Volume Lordo - <i>Gross volume</i>	472 l
Potenza - <i>Power</i>	440 W
Consumo - <i>Consumption</i>	4,7 kWh/24h
Dimensioni imballo (L x p x h) - <i>Packaging sizes (w x d x h)</i>	755 x 705 x 2133 mm
Dati per il trasporto - <i>Transport data (20 ft - 40 ft - 40 hc - 13,60 mt)</i>	21/48/48/57
Ripiani - <i>Shelves</i>	5 rimovibili / removable
Classe energetica - <i>Energy efficiency class</i>	

✓ **Più di 300.000 unità vendute nel mondo**  
Over 300.000 units sold in the world

✓ **Ideale per ogni tipo di alimento fresco**  
Ideal for any kind of fresh food

✓ **Facilmente personalizzabile**  
Easy to brand

✓ **Struttura robusta anti deterioramento**  
Anti deterioration strong structure

✓ **Rispetto ambientale: Gas R290**  
Environmentally friendly: R290 Gas

**APPROFONDIMENTO - More details**

**Esterno ed interno in lamiera d'acciaio preverniciata bianca trattata anti corrosione (mod. W)**  
Exterior and interior in white pre-painted sheet steel anti-corrosion treated (mod. W)

**Esterno in lamiera preverniciata nera, interno in lamiera preverniciata bianca (mod. B)**  
Exterior in black pre-painted sheet metal, interior in white pre-painted sheet metal (mod. B)

**Evaporatore ventilato a pacco alettato**  
Ventilated pack evaporator

**Termostato-termometro elettronico con sbrinamento automatico**  
Electronic thermostat-thermometer with automatic defrosting

**2x Luce interna verticale a LED**  
2x Vertical internal LED light

**2 piedini regolabili + 4 rullini**  
2 adjustable feet+ 4 rollers

**Serratura**  
Lock

MOD. B

**ACCESSORI - Accessories**

Cod.	Optional	Modelli - Models
4420145510000	Griglia plastificata bianca - White plasticized shelf (580 x 409 mm)	EXPO 400 PT
3401100000100	Supporto con piolo (4 per griglia) - Hook (4 for each shelf)	EXPO 400 PT
3306105405002	Profili portaprezzi - Price holder profile	EXPO 400 PT



# Murales

Espositori murali ventilati  
Ventilated multidecks



TEMPERATURE RANGE

0° +4° C

IDEAL FOR



## CARATTERISTICHE TECNICHE - Technical features

	MURALES 7	MURALES 10	MURALES 14	MURALES 19
Temperatura - Temperature	0°C +4°C	0°C +4°C	0°C +4°C	0°C +4°C
Gas refrigerante - Refrigerant gas	R290	R290	R290	R290
Classe climatica - Climate Class	3 (25°C-60%UR) M1	3 (25°C-60%UR) M1	3 (25°C-60%UR) M1	3 (25°C-60%UR) M1
Dimensioni (l x p x h) - Sizes (w x d x h)	685x 640 x 1981 mm	985 x 640 x 1981 mm	1335 x 640 x 1981 mm	1885 x 640 x 1981 mm
Peso netto - Net weight	126 kg	162 kg	188 kg	243 kg
Peso lordo - Gross weight	142 kg	180 kg	210 kg	272 kg
Volume Netto - Net volume	318 l	447 l	663 l	954 l
Volume Lordo - Gross volume	438 l	657 l	913 l	1314 l
Potenza - Power	700 W	800 w	920 W	1250 W
Consumo - Consumption	13 kWh/24h	13,7 kWh/24h	19,1 kWh/24h	25 kWh/24h
Dimensioni imballo (l x p x h) - Packaging sizes (w x d x h)	750 x 750 x 2100 mm	1050 x 750 x 2100 mm	1400 x 750 x 2100 mm	1950 x 750 x 2100 mm
Dati per il trasporto - Transport data (20 ft - 40 ft - 40 hc - 13,60 mt)	21/48/48/51	15/33/33/36	12/24/24/27	9/18/18/18
Ripiani - Shelves	4	4	4	4
Classe energetica - Energy efficiency class				

✓ **Fino a 1.200 € di risparmio annuo sui consumi energetici\***  
Up to 1.200 €/year of energy saving\*

\*Costo medio / Average cost € 0,29 kWh  
MURALES 19 vs Modelli simili sul mercato (similar models available on the market)

✓ **Spalle interne a specchio per esaltare il prodotto esposto**  
End-walls in AISI 304 mirror finish to highlight the displayed product

✓ **Ideale per ogni tipo di alimento fresco**  
Ideal for any kind of fresh food

✓ **Ideale anche per negozi con spazi ridotti (profondità 64 cm)**  
Ideal also for small shops with reduced spaces (depth 64 cm)

✓ **Tenda notte di serie**  
Night curtain as standard

✓ **Rispetto ambientale: Gas R290**  
Environmentally friendly: R290 Gas

✓ **Piastra motore estraibile per facilitare le operazioni di manutenzione e pulizia**  
Extractable engine compartment to ease the maintenance and cleaning operations

## APPROFONDIMENTO - More details

**Esterno ed interno in lamiera d'acciaio preverniciata bianca trattata anti corrosione (mod. W)**

Exterior and interior in white pre-painted sheet steel anti-corrosion treated (mod. W)

**Esterno in lamiera preverniciata nera, interno in lamiera preverniciata nera (mod. B)**

Exterior in black pre-painted sheet metal, interior in black pre-painted sheet metal (mod. B)

**Esterno in lamiera preverniciata grigio/SILVER, interno in acciaio inox AISI 304 (mod. X)**

Exterior in grey/SILVER pre-painted sheet metal, interior in AISI 304 stainless steel (mod. X)

**Spalle interne a specchio**

End-walls in mirror finish AISI 304

**Ripiani profondità 34,5 cm. inclinabili**

34,5 cm deep tilting shelves

**2x Luce interna verticale a LED**

2x Vertical internal LED light

**Luce interna orizzontale a LED (mod. 19)**

Horizontal internal LED light (mod. 19)

**Piedi regolabili - Adjustable feet**



MOD. B

MOD. X

## ACCESSORI - Accessories

Optional	MURALES 7	MURALES 10	MURALES 14	MURALES 19
Kit fermaprodotto in plexiglass - Plexiglass riser kit	8808069	8808070	8808071	8808072
Kit griglia fermaprodotto in filo plastificato - Plasticized riser kit	○ 8808061 mod.W ● 8808249 mod. B/G	○ 8808028 mod.W ● 8808234 mod. B/G	○ 8808029 mod.W ● 8808235 mod. B/G	○ 8808030 mod.W ● 8808236 mod. B/G
Kit ripiano - Shelf kit	○ 8808246 mod.W ● 8808247 mod. B ○ 8808248 mod. X	○ 8808237 mod.W ● 8808240 mod. B ○ 8808243 mod. X	○ 8808238 mod.W ● 8808241 mod. B ○ 8808244 mod. X	○ 8808239 mod.W ● 8808242 mod. B ○ 8808245 mod. X

○ BIANCO/WHITE ● GRIGIO/GREY ● NERO/BLACK ○ INOX/SS

Cod.	Optional	Modelli - Models
8808215	Kit 4 ruote gemellate diametro 75mm (2 con freno) - 4 Twin castor kit (2 with brake)	MURALES 10 / 14
8998160F	Dispositivo d'evaporazione aggiuntivo acqua di condensa - Additional evaporation water system	TUTTI - ALL



## Murales SD

Espositori murali ventilati con porte scorrevoli  
Ventilated multidecks with sliding doors



TEMPERATURE RANGE

0° +4° C

IDEAL FOR



**CARATTERISTICHE TECNICHE - Technical features**

	MURALES SD 10	MURALES SD 14	MURALES SD 19
Temperatura - Temperature	0°C +4°C	0°C +4°C	0°C +4°C
Gas refrigerante - Refrigerant gas	R290	R290	R290
Classe climatica - Climate Class	3 (25°C-60%UR) M1	3 (25°C-60%UR) M1	3 (25°C-60%UR) M1
Dimensioni (l x p x h) - Sizes (w x d x h)	985 x 640 x 1981 mm	1335 x 640 x 1981 mm	1885 x 640 x 1981 mm
Peso netto - Net weight	168 kg	205 kg	278 kg
Peso lordo - Gross weight	186 kg	227 kg	307 kg
Volume Netto - Net volume	445 l	660 l	949 l
Volume Lordo - Gross volume	657 l	913 l	1314 l
Potenza - Power	430 w	520 W	870 W
Consumo - Consumption	4,75 kWh/24h	4,89 kWh/24h	6,37 kWh/24h
Dimensioni imballo (l x p x h) - Packaging sizes (w x d x h)	1050 x 750 x 2100 mm	1400 x 750 x 2100 mm	1950 x 750 x 2100 mm
Dati per il trasporto - Transport data (20 ft - 40 ft - 40 hc - 13,60 mt)	15/33/33/36	12/24/24/27	9/18/18/18
Ripiani - Shelves	4	4	4
Classe energetica - Energy efficiency class			

**✓ Fino a 3.000 € di risparmio annuo sui consumi energetici\***

Up to 3.000 €/year of energy saving\*

\*Costo medio / Average cost € 0,50 kWh MURALES 19 SD vs Modelli aperti simili sul mercato (similar open models available on the market)

**✓ Spalle interne a specchio per esaltare il prodotto esposto**

End-walls in AISI 304 mirror finish to highlight the displayed product

**✓ Ideale per ogni tipo di alimento fresco**

Ideal for any kind of fresh food

**✓ Ideale anche per negozi con spazi ridotti (profondità 64 cm)**

Ideal also for small shops with reduced spaces (depth 64 cm)

**✓ Rispetto ambientale: Gas R290**

Environmentally friendly: R290 Gas

**✓ Piastra motore estraibile per facilitare le operazioni di manutenzione e pulizia**

Extractable engine compartment to ease the maintenance and cleaning operations

**APPROFONDIMENTO - More details**
**Esterno ed interno in lamiera d'acciaio preverniciata bianca trattata anti corrosione (mod. W)**

Exterior and interior in white pre-painted sheet steel anti-corrosion treated (mod. W)

**Esterno in lamiera preverniciata nera, interno in lamiera preverniciata nera (mod. B)**

Exterior in black pre-painted sheet metal, interior in black pre-painted sheet metal (mod. B)

**Esterno in lamiera preverniciata grigio/SILVER, interno in acciaio inox AISI 304 (mod. X)**

Exterior in grey/SILVER pre-painted sheet metal, interior in AISI 304 stainless steel (mod. X)

**2x Porta scorrevole**

2x Sliding door

**Spalle interne a specchio**

End-walls in mirror finish AISI 304

**Ripiani profondità 39 cm. inclinabili**

39 cm deep tilting shelves

**2x Luce interna verticale a LED**

2x Vertical internal LED light

**Luce interna orizzontale a LED (mod. 19)**

Horizontal internal LED light (mod. 19)

**Piedi regolabili - Adjustable feet**

MOD. B

MOD. X

**ACCESSORI - Accessories**

Optional	MURALES SD 10	MURALES SD 14	MURALES SD 19
Kit fermaprodotto in plexiglass - Plexiglass riser kit	8808070	8808071	8808072
Kit griglia fermaprodotto in filo plastificato - Plasticized riser kit	○ 8808028 mod.W ● 8808234 mod. B/G	○ 8808029 mod.W ● 8808235 mod. B/G	○ 8808030 mod.W ● 8808236 mod. B/G
Kit ripiano - Shelf kit	○ 8808237 mod.W ● 8808240 mod. B ● 8808243 mod. X	○ 8808238 mod.W ● 8808241 mod. B ● 8808244 mod. X	○ 8808239 mod.W ● 8808242 mod. B ● 8808245 mod. X

○ BIANCO/WHITE ● GRIGIO/GREY ● NERO/BLACK ● INOX/SS

Cod.	Optional	Modelli - Models
8808215	Kit 4 ruote gemellate diametro 75mm (2 con freno) - 4 Twin castor kit (2 with brake)	MURALES SD 10 / SD 14
8998160F	Dispositivo d'evaporazione aggiuntivo acqua di condensa - Additional evaporation water system	TUTTI - ALL



# Murales HD

Espositori murali ventilati con porte battenti  
Ventilated multidecks with hinged doors



TEMPERATURE RANGE

0° +4° C

IDEAL FOR





**CARATTERISTICHE TECNICHE - Technical features**

	MURALES HD 10	MURALES HD 14	MURALES HD 19
Temperatura - Temperature	0°C +4°C	0°C +4°C	0°C +4°C
Gas refrigerante - Refrigerant gas	R290	R290	R290
Classe climatica - Climate Class	3 (25°C-60%UR) M1	3 (25°C-60%UR) M1	3 (25°C-60%UR) M1
Dimensioni (l x p x h) - Sizes (w x d x h)	985 x 640 x 1981 mm	1335 x 640 x 1981 mm	1885 x 640 x 1981 mm
Peso netto - Net weight	168 kg	205 kg	278 kg
Peso lordo - Gross weight	186 kg	227 kg	307 kg
Volume Netto - Net volume	445 l	660 l	949 l
Volume Lordo - Gross volume	657 l	913 l	1314 l
Potenza - Power	430 w	520 W	870 W
Consumo - Consumption	4,75 kWh/24h	4,89 kWh/24h	6,37 kWh/24h
Dimensioni imballo (l x p x h) - Packaging sizes (w x d x h)	1050 x 750 x 2100 mm	1400 x 750 x 2100 mm	1950 x 750 x 2100 mm
Dati per il trasporto - Transport data (20 ft - 40 ft - 40 hc - 13,60 mt)	15/33/33/36	12/24/24/27	9/18/18/18
Ripiani - Shelves	4	4	4
Classe energetica - Energy efficiency class			

**✓ Fino a 3.000 € di risparmio annuo sui consumi energetici\***

Up to 3.000 €/year of energy saving\*

 \*Costo medio / Average cost € 0,50 kWh  
 MURALES 19 HD vs Modelli aperti simili sul mercato  
 (similar open models available on the market)

**✓ Spalle interne a specchio per esaltare il prodotto esposto**

End-walls in AISI 304 mirror finish to highlight the displayed product

**✓ Ideale per ogni tipo di alimento fresco**

Ideal for any kind of fresh food

**✓ Ideale anche per negozi con spazi ridotti (profondità 64 cm)**

Ideal also for small shops with reduced spaces (depth 64 cm)

**✓ Rispetto ambientale: Gas R290**

Environmentally friendly: R290 Gas

**✓ Piastra motore estraibile per facilitare le operazioni di manutenzione e pulizia**

Extractable engine compartment to ease the maintenance and cleaning operations

**APPROFONDIMENTO - More details**
**Esterno ed interno in lamiera d'acciaio preverniciata bianca trattata anti corrosione (mod. W)**

Exterior and interior in white pre-painted sheet steel anti-corrosion treated (mod. W)

**Esterno in lamiera preverniciata nera, interno in lamiera preverniciata nera (mod. B)**

Exterior in black pre-painted sheet metal, interior in black pre-painted sheet metal (mod. B)

**Esterno in lamiera preverniciata grigio/SILVER, interno in acciaio inox AISI 304 (mod. X)**

Exterior in grey/SILVER pre-painted sheet metal, interior in AISI 304 stainless steel (mod. X)

**2x Porta battente (mod. 10 e 14)**
**4x Porta battente (mod. 19)**

2x Hinged door (mod. 10 and 14)

4x Hinged door (mod. 19)

**Spalle interne a specchio**

End-walls in mirror finish AISI 304

**Ripiani profondità 39 cm. inclinabili**

39 cm deep tilting shelves

**2x Luce interna verticale a LED**

2x Vertical internal LED light

**Luce interna orizzontale a LED (mod. 19)**

Horizontal internal LED light (mod. 19)

**Piedi regolabili - Adjustable feet**

MOD. W

MOD. X

**ACCESSORI - Accessories**

Optional	MURALES HD 10	MURALES HD 14	MURALES HD 19
Kit fermaprodotto in plexiglass - Plexiglass riser kit	8808070	8808071	8808072
Kit griglia fermaprodotto in filo plastificato - Plasticized riser kit	○ 8808028 mod.W ● 8808234 mod. B/G	○ 8808029 mod.W ● 8808235 mod. B/G	○ 8808030 mod.W ● 8808236 mod. B/G
Kit ripiano - Shelf kit	○ 8808237 mod.W ● 8808240 mod. B ● 8808243 mod. X	○ 8808238 mod.W ● 8808241 mod. B ● 8808244 mod. X	○ 8808239 mod.W ● 8808242 mod. B ● 8808245 mod. X

○ BIANCO/WHITE ● GRIGIO/GREY ● NERO/BLACK ● INOX/SS

Cod.	Optional	Modelli - Models
8808215	Kit 4 ruote gemellate diametro 75mm (2 con freno) - 4 Twin castor kit (2 with brake)	MURALES HD 10 / HD 14
8998160F	Dispositivo d'evaporazione aggiuntivo acqua di condensa - Additional evaporation water system	TUTTI - ALL



# Supersunny SD

Espositori murali con porte scorrevoli  
Wall site multidecks with sliding doors



TEMPERATURE RANGE

0° +10° C

IDEAL FOR



**CARATTERISTICHE TECNICHE - Technical features**

	<b>SUPERSUNNY SD 10 GLASS</b>	<b>SUPERSUNNY SD 14 GLASS</b>	<b>SUPERSUNNY SD 19 GLASS</b>
Temperatura - <i>Temperature</i>	0°C +10°C	0°C +10°C	0°C +10°C
Gas refrigerante - <i>Refrigerant gas</i>	R290	R290	R290
Classe climatica - <i>Climate Class</i>	4 (30°C-55%UR) M1	4 (30°C-55%UR) M1	4 (30°C-55%UR) M1
Dimensioni (L x p x h) - <i>Sizes (w x d x h)</i>	985 x 737 x 1987 mm	1335 x 737 x 1987 mm	1885 x 737 x 1987 mm
Peso netto - <i>Net weight</i>	216 kg	247 kg	327 kg
Peso lordo - <i>Gross weight</i>	226 kg	271 kg	346 kg
Volume Netto - <i>Net volume</i>	601 l	825 l	1180 l
Volume Lordo - <i>Gross volume</i>	685 l	940 l	1340 l
Potenza - <i>Power</i>	750 W	930 W	1200 W
Consumo - <i>Consumption</i>	9,02 kWh/24h	8,94 kWh/24h	13,13 kWh/24h
Dimensioni imballo (L x p x h) - <i>Packaging sizes (w x d x h)</i>	1090 x 760 x 2120 mm	1440 x 760 x 2120 mm	1990 x 760 x 2120 mm
Dati per il trasporto - <i>Transport data (20 ft - 40 ft - 40 hc - 13,60 mt)</i>	15/33/33/36	12/24/24/27	8/18/18/19
Ripiani - <i>Shelves</i>	4	4	4
Classe energetica - <i>Energy efficiency class</i>			

✓ **Fino a 2.450 € di risparmio annuo sui consumi energetici\***

Up to 2.450 €/year of energy saving\*

\*Costo medio / Average cost € 0,29 kWh SUPERSUNNY 19 GLASS vs Murali aperti di vecchia generazione (Older multidecks models)

✓ **Ideale per ogni tipo di alimento fresco**

Ideal for any kind of fresh food

✓ **3 Ampi lati vetrati per una massima visibilità**

3 Wide side glasses for maximum visibility

✓ **Massima capacità grazie ai ripiani profondi 48 cm.**

Maximum capacity thanks to 48 cm. depth shelves

✓ **Struttura robusta anti deterioramento**

Anti deterioration strong structure

✓ **Rispetto ambientale: Gas R290**

Environmentally friendly: R290 Gas

**APPROFONDIMENTO - More details**

**Esterno in lamiera preverniciata grigio/SILVER, interno in lamiera preverniciata bianca (mod. G)**

Exterior in grey/SILVER pre-painted metal sheet, interior in white pre-painted metal sheet (mod. G)

**Esterno in lamiera preverniciata nera, interno in lamiera preverniciata nera (mod. B)**

Exterior in black pre-painted metal sheet, interior in black pre-painted metal sheet (mod. B)

**Vetri laterali in cristallo doppio basso emissivo**

Double low-emissivity lateral glasses

**Ripiani inclinabili con portaprezzi adesivo**

Tilting shelves with adhesive price holder

**2x Luce interna verticale a LED**

2x Vertical internal LED light

**Luce interna orizzontale a LED (mod. 19)**

Horizontal internal LED light (mod. 19)

**Batticarrello nero**

Black bumper

**Piedini regolabili**

Adjustable feet



MOD. G

**ACCESSORI - Accessories**

Optional	<b>SUPERSUNNY 10</b>	<b>SUPERSUNNY 14</b>	<b>SUPERSUNNY 19</b>
<i>Kit fermaprodotto in plexiglass - Plexiglass riser kit</i>	8808070	8808071	8808072
<i>Kit griglia fermaprodotto in filo plastificato - Plasticized riser kit</i>	○ 8808028 mod.G ● 8808234 mod. B	○ 8808029 mod.G ● 8808235 mod. B	○ 8808030 mod.G ● 8808236 mod. B
<i>Kit ripiano - Shelf kit</i>	○ 8808173 mod.G ● 8808250 mod. B	○ 8808174 mod.G ● 8808251 mod. B	○ 8808175 mod.G ● 8808252 mod. B
<i>Kit canalizzazione - Multiplexing kit</i>	● 8808172 mod.G ● 8808253 mod. B	● 8808172 mod.G ● 8808253 mod. B	● 8808172 mod.G ● 8808253 mod. B

○ BIANCO/WHITE ● GRIGIO/GREY ● NERO/BLACK

Cod. Optional

8808040 *Kit 4 ruote gemellate Ø 75 mm (2 con freno) - 4 Twin castors kit Ø 75 mm (2 with brake)*

Modelli - *Models*

TUTTI - ALL



# Supersunny HD

Espositori murali con porte battenti  
Wall site multidecks with hinged doors



TEMPERATURE RANGE

0° +10° C

IDEAL FOR



**CARATTERISTICHE TECNICHE - Technical features**

	<b>SUPERSUNNY HD 10 GLASS</b>	<b>SUPERSUNNY HD 14 GLASS</b>	<b>SUPERSUNNY HD 19 GLASS</b>
Temperatura - <i>Temperature</i>	0°C +10°C	0°C +10°C	0°C +10°C
Gas refrigerante - <i>Refrigerant gas</i>	R290	R290	R290
Classe climatica - <i>Climate Class</i>	4 (30°C-55%UR) M1	4 (30°C-55%UR) M1	4 (30°C-55%UR) M1
Dimensioni (L x p x h) - <i>Sizes (w x d x h)</i>	985 x 737 x 1987 mm	1335 x 737 x 1987 mm	1885 x 737 x 1987 mm
Peso netto - <i>Net weight</i>	216 kg	247 kg	327 kg
Peso lordo - <i>Gross weight</i>	226 kg	271 kg	346 kg
Volume Netto - <i>Net volume</i>	601 l	825 l	1180 l
Volume Lordo - <i>Gross volume</i>	685 l	940 l	1340 l
Potenza - <i>Power</i>	750 W	930 W	1200 W
Consumo - <i>Consumption</i>	9,02 kWh/24h	8,94 kWh/24h	13,13 kWh/24h
Dimensioni imballo (L x p x h) - <i>Packaging sizes (w x d x h)</i>	1090 x 760 x 2120 mm	1440 x 760 x 2120 mm	1990 x 760 x 2120 mm
Dati per il trasporto - <i>Transport data (20 ft - 40 ft - 40 hc - 13,60 mt)</i>	15/33/33/36	12/24/24/27	8/18/18/19
Ripiani - <i>Shelves</i>	4	4	4
Classe energetica - <i>Energy efficiency class</i>			

**✓ Fino a 2.450 € di risparmio annuo sui consumi energetici\***

Up to 2.450 €/year of energy saving\*

\*Costo medio / Average cost € 0,29 kWh SUPERSUNNY 19 GLASS vs Murali aperti di vecchia generazione (Older multidecks models)

**✓ Ideale per ogni tipo di alimento fresco**

Ideal for any kind of fresh food

**✓ 3 Ampi lati vetrati per una massima visibilità**

3 Wide side glasses for maximum visibility

**✓ Massima capacità grazie ai ripiani profondi 48 cm.**

Maximum capacity thanks to 48 cm. depth shelves

**✓ Struttura robusta anti deterioramento**

Anti deterioration strong structure

**✓ Rispetto ambientale: Gas R290**

Environmentally friendly: R290 Gas

**APPROFONDIMENTO - More details**
**Esterno in lamiera preverniciata grigio/SILVER, interno in lamiera preverniciata bianca (mod. G)**

Exterior in grey/SILVER pre-painted metal sheet, interior in white pre-painted metal sheet (mod. G)

**Esterno in lamiera preverniciata nera, interno in lamiera preverniciata nera (mod. B)**

Exterior in black pre-painted metal sheet, interior in black pre-painted metal sheet (mod. B)

**Vetri laterali in cristallo doppio basso emissivo**

Double low-emissivity lateral glasses

**Ripiani inclinabili con portaprezzi adesivo**

Tilting shelves with adhesive price holder

**2x Luce interna verticale a LED**

2x Vertical internal LED light

**Luce interna orizzontale a LED (mod. 19)**

Horizontal internal LED light (mod. 19)

**Batticarrello nero**

Black bumper

**Piedini regolabili**

Adjustable feet



MOD. B

**ACCESSORI - Accessories**

Optional	<b>SUPERSUNNY 10</b>	<b>SUPERSUNNY 14</b>	<b>SUPERSUNNY 19</b>
<i>Kit fermaprodotto in plexiglass - Plexiglass riser kit</i>	8808070	8808071	8808072
<i>Kit griglia fermaprodotto in filo plastificato - Plasticized riser kit</i>	○ 8808028 mod.G ● 8808234 mod. B	○ 8808029 mod.G ● 8808235 mod. B	○ 8808030 mod.G ● 8808236 mod. B
<i>Kit ripiano - Shelf kit</i>	○ 8808173 mod.G ● 8808250 mod. B	○ 8808174 mod.G ● 8808251 mod. B	○ 8808175 mod.G ● 8808252 mod. B
<i>Kit canalizzazione - Multiplexing kit</i>	● 8808172 mod.G ● 8808253 mod. B	● 8808172 mod.G ● 8808253 mod. B	● 8808172 mod.G ● 8808253 mod. B

○ BIANCO/WHITE ● GRIGIO/GREY ● NERO/BLACK

Cod. Optional

 8808040 *Kit 4 ruote gemellate Ø 75 mm (2 con freno) - 4 Twin castors kit Ø 75 mm (2 with brake)*

 Modelli - *Models*

TUTTI - ALL